

**TOLERANCES**

DIMENSIONS ARE IN INCHES  
UNLESS OTHERWISE SHOWN  
FRACTIONAL: ..... ±1/16  
ANGULAR: ..... ±1°  
TWO PLACE DECIMAL: .... ±.01  
THREE PLACE DECIMAL: .. ±.005

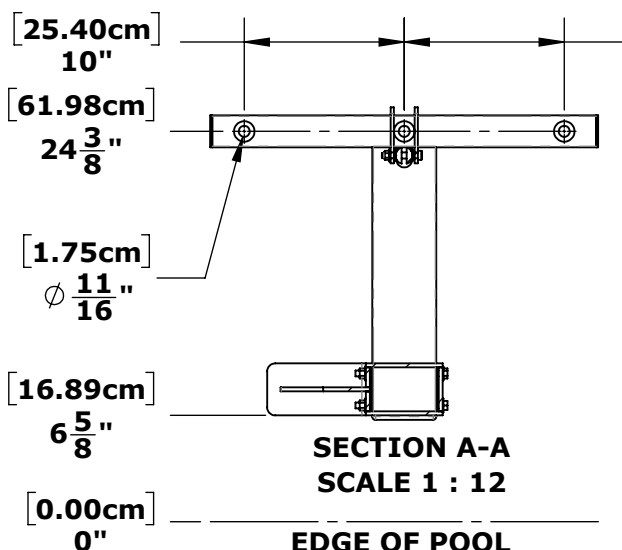
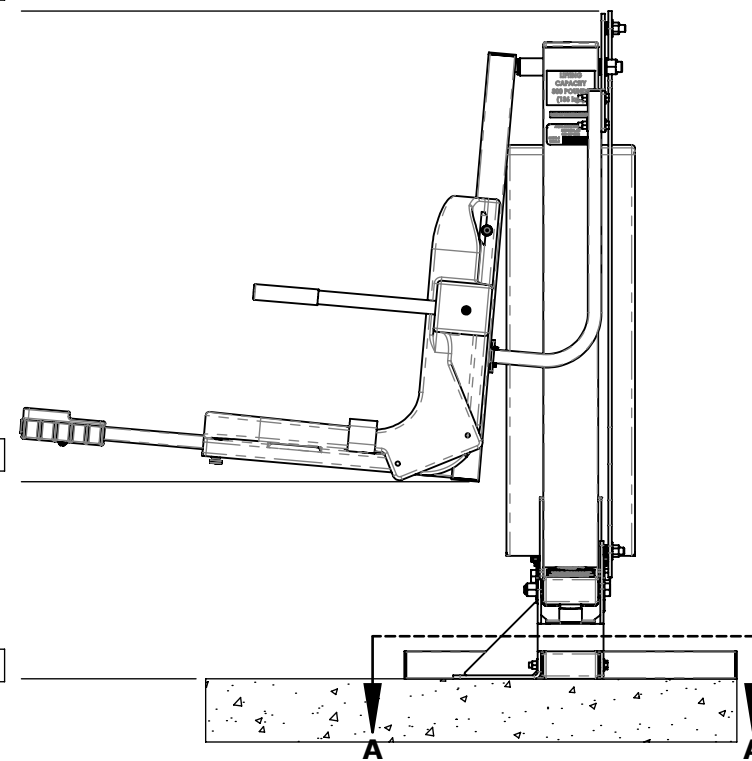
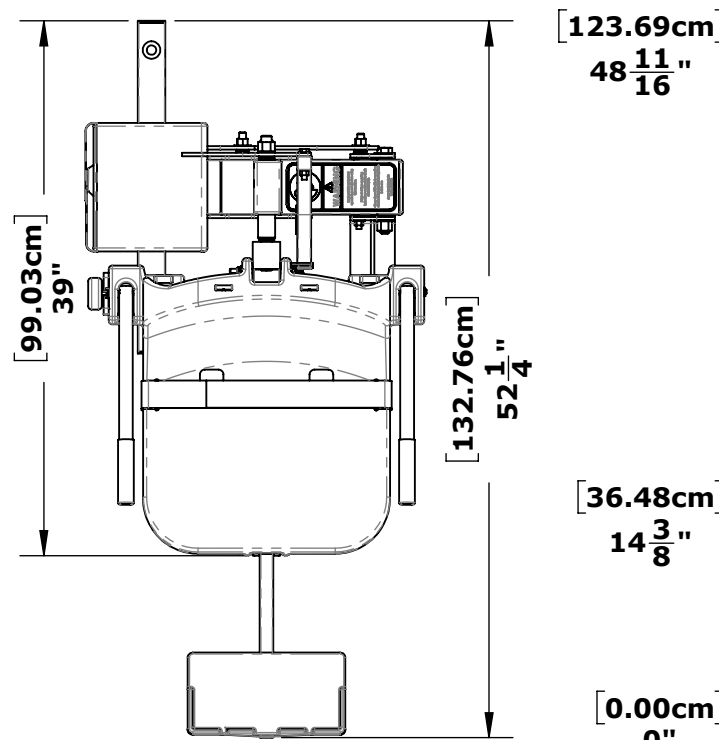
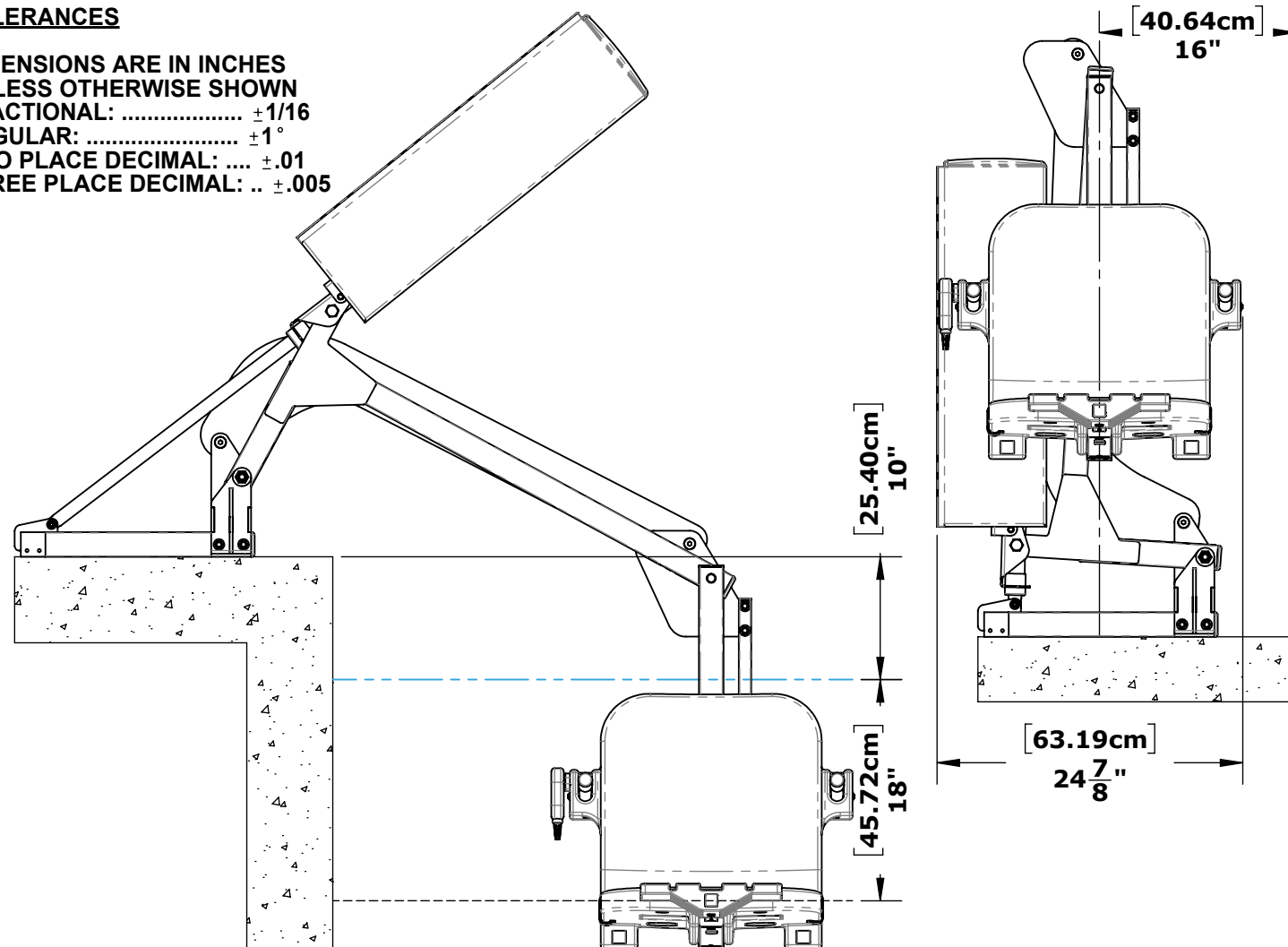

**FEATURES**

- ◆ UL CERTIFIED ◆ 300 LB. (136 KG.) WEIGHT CAPACITY
- ◆ SETBACK RANGE 19" TO 38" (49 - 96 cm)
- ◆ INDEPENDENT THIRD PARTY VERIFIED TO MEET ADA STANDARDS
- ◆ CLEARANCES VARY BY WALL HEIGHT & WIDTH
- ◆ FLIP UP ARMREST
- ◆ ALL STAINLESS STEEL CONSTRUCTION
- ◆ DURABLE POWDER COAT FINISH
- ◆ RECHARGEABLE BATTERY & WALL MOUNT CHARGER
- ◆ FIVE YEAR STRUCTURAL WARRANTY
- ◆ FIVE YEAR PRO-RATED ELECTRONICS WARRANTY

CLICK HERE TO VIEW THIS PRODUCT:  
[HTTPS://AQUACREEKPRODUCTS.COM/AMBASSADOR/](https://aquacreekproducts.com/ambassador/)

**AMBASSADOR**  
U.S. PATENT NO. 7,249,386 B2 & D507,7695  
PART NO. F-PPXRD-NA

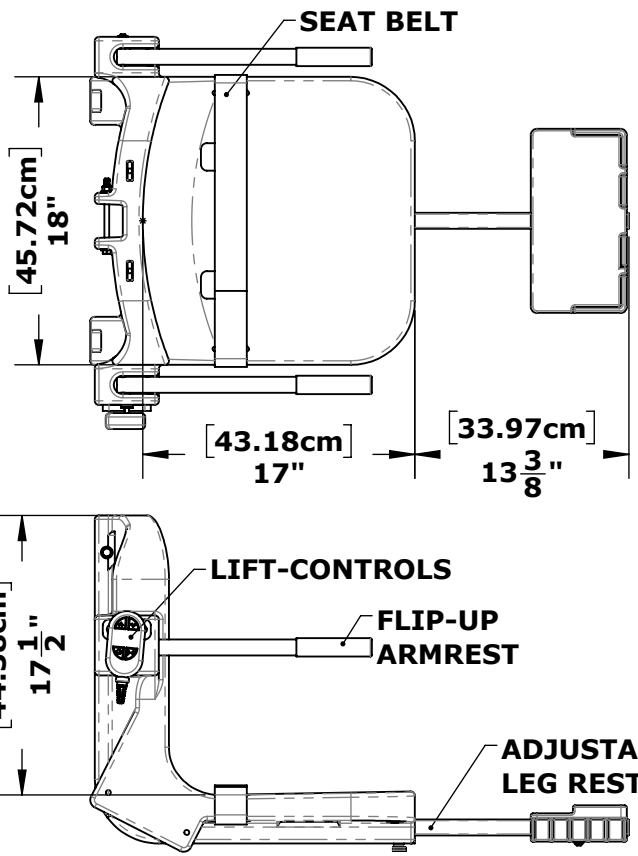

MATERIAL: 304 STAINLESS STEEL  
FINISH: POWDER COAT - WHITE  
APPROX. WEIGHT: 133.993 LBS.



9889 GARRYMORE LANE  
MISSOULA, MT 59808  
(406) 549-0769  
FAX (406) 549-2602  
www.AquaCreek.com

PROPRIETARY AND CONFIDENTIAL INFORMATION  
THIS DRAWING AND ALL INFORMATION CONTAINED HEREIN IS THE SOLE PROPERTY OF AQUA CREEK PRODUCTS LLC. ANY REPRODUCTION IN PART OR AS A WHOLE WITHOUT WRITTEN PERMISSION FROM AQUA CREEK IS PROHIBITED.  
\*SPECIFICATIONS ARE SUBJECT TO CHANGE WITHOUT NOTICE

REVISIONS			
REV.	DESCRIPTION	DATE	APPROVED
P1	PRODUCTION RELEASE	4/27/2021	J.MAXWELL