



FUTURE
MOBILITY HEALTHCARE INC.

ORION



USER MANUAL

470 – ORION II REV04 REV12/17/2018

1 CONTACT INFORMATION

FUTURE MOBILITY HEALTHCARE INC. APPRECIATES YOUR FEEDBACK

Supplier: Please give this manual to the user of the wheelchair.

User: Please read this entire manual before using this wheelchair.
Thank you for choosing Future Mobility Healthcare Inc.
If you have any questions please do not hesitate to write or call us
at the address and telephone number below:

Future Mobility Healthcare Inc.

Customer Service Canada

6750 Professional Court

Mississauga ON L4V 1X6

Phone: (888) 737-4011 or (905) 671-1661

Fax: (905) 671-3377

e-mail: orderdesk@futuremobility.ca

www.futuremobility.ca

TABLE OF CONTENTS

1	CONTACT INFORMATION	2
	TABLE OF CONTENTS	3
2	NOTICE – READ BEFORE USE	5
	CHOOSE THE CORRECT CHAIR AND OPTIONS.....	5
	REVIEW THIS MANUAL OFTEN.....	5
	WARNING.....	5
3	GENERAL	6
	USER WEIGHT LIMIT.....	6
	WEIGHT TRAINING.....	6
	GETTING TO KNOW YOUR CHAIR.....	6
	TO REDUCE THE RISK.....	6
	SAFETY CHECKLIST.....	6
	CHANGES AND ADJUSTMENTS.....	7
	GROUND TERRAIN.....	7
	CENTER OF GRAVITY.....	7
	WHEELIES.....	7
	ROLLING BACKWARDS.....	8
	REACHING OR LEANING.....	8
	RAMPS AND SLOPES.....	8
	TRANSFERS.....	9
4	ATTENDANT WARNINGS	9
	TILTING THE WHEELCHAIR.....	9
	DESCENDING A CURB.....	9
	CLIMBING A CURB.....	10
	DESCENDING STAIRS.....	10
5	COMPONENT WARNINGS	11
	ANTI-TIP WHEELS.....	11
	ARMRESTS.....	11

	BACK CANES.....	11
	FASTENERS.....	11
	FOOTRESTS.....	12
	POSITIONING BELTS.....	12
	QUICK-RELEASE AXLES.....	12
	REAR WHEEL LOCKS.....	13
	FEATURES.....	14
	SAFETY INSPECTION CHECKLIST.....	15
	TROUBLESHOOTING.....	17
	LABELS.....	18
6	T-STYLE KNOB RELEASE ARM RESTS	19
	INSTALLING AND REMOVING T-STYLE ARM RESTS (FIGURE 1).....	19
7	FLIP-UP ARM RESTS	20
	ENGAGING/DISENGAGING AND ADJUSTING FLIP-UP STYLE ARM REST (FIGURE 2).....	20
8	T-STYLE PIN RELEASE ARM RESTS	21
	ADJUSTING AND INSTALLING T-STYLE PIN RELEASE ARMRESTS (FIGURE 3).....	21
9	PIN STYLE SWINGAWAY LEG REST	22
	INSTALLING AND ADJUSTING PIN STYLE LEG RESTS AND FOOT PLATE (FIGURE 4).....	22
10	CENTER PIVOT SWINGAWAY LEGREST	23
	INSTALLING AND REMOVING CENTER PIVOT SWINGAWAY LEG RESTS AND FOOT PLATE (FIGURE 5).....	23
11	CENTER PIVOT DUAL SWINGAWAY LEGREST	24
	INSTALLING AND REMOVING CENTER PIVOT SWINGAWAY LEG RESTS AND FOOT PLATE (FIGURE 6).....	24
12	CENTER PIVOT SWINGAWAY ELEVATING LEGREST	25
	INSTALLING AND ADJUSTING LEG RESTS AND FOOT PLATE (FIGURE 7, FIGURE 8).....	25
13	FIXED BACK/CANE STROLLER BAR	27

ADJUSTING BACK ANGLE (FIGURE 9, FIGURE 10)	27
14 FOLD DOWN BACK CANE/STROLLER BAR	28
ADJUSTING ANGLE AND FOLDING DOWN BACK (FIGURE 11, FIGURE 12)	28
15 RECLINE BACK CANE STROLLER/BAR	29
RECLINING THE BACK (FIGURE 13, FIGURE 14)	29
16 HINGED STROLLER BAR (ANGLE ADJUSTABLE)	30
ADJUSTING ANGLE OF STROLLER BAR (FIGURE 15)	30
17 RECLINE CYLINDER INSTALLATION	31
INSTALLING RECLINE CYLINDER (FIGURE 16)	31
18 REAR WHEEL POSITIONING	32
INSTALLING AND POSITIONING REAR WHEELS (FIGURE 17-19)	32
19 WHEEL LOCKS	34
OPERATING WHEEL LOCKS (FIGURE 20, FIGURE 21)	34
20 ADJUSTING THE PATIENT OPERATED WHEEL LOCKS ...	35
21 FRONT CASTERS	36
INSTALLING AND REMOVING FORKS AND CASTERS (FIGURE 22-25)	36
22 ANTI-TIPPERS	40
INSTALLING/ ADJUSTING ANTI-TIPPERS (FIGURE 26, FIGURE 27)	40
23 CABLE ADJUSTMENT PROCEDURE	43
ADJUSTING RECLINE CABLE (FIGURE 28, FIGURE 29)	43
24 MAINTENANCE	45
GENERAL MAINTENANCE	45
SERVICE AND REPAIR	45
CLEANING YOUR CHAIR	45
25 WARRANTY	47
LIFETIME	47
FOR TWO (2) YEARS	47
FOR (90) DAYS	47
LIMITATIONS	48
WARRANTY PROCEDURES	48

2 NOTICE – READ BEFORE USE

CHOOSE THE CORRECT CHAIR AND OPTIONS

Future Mobility Healthcare Inc. provides a choice of many wheelchair styles to meet the requirements of the wheelchair user. However, the final selection of the wheelchair and its options rests solely with you and your health care advisor. Choosing the best chair will depend on such things as:

1. The level of your disability, strength, balance and coordination.
2. The places and terrain that you are likely to use your chair.
3. The need for options for your safety and comfort (such as anti-tip tubes, positioning belts, or special seating systems).

REVIEW THIS MANUAL OFTEN

Before using this chair you, and each person who may assist you, should read this entire manual and make sure to follow all instructions. Review the warnings often.

WARNING

The term “**WARNING**” are hazards or unsafe practices that may cause **severe injury or death** to you or to other persons.

3 General

USER WEIGHT LIMIT



WARNING

NEVER exceed the weight limit of 250 pounds for a combined weight of rider and items carried. If you do exceed the limit, damage to your chair, tip-over or loss of control may occur and cause severe injury to the rider or others.

WEIGHT TRAINING



WARNING

NEVER use this chair for weight training if total weight (rider plus equipment) exceeds 250 pounds. If you do exceed the limit, damage to your chair, tip-over or loss of control may occur and cause severe injury to the rider or others.

GETTING TO KNOW YOUR CHAIR



WARNING

Every wheelchair is different. Take the time to learn the feel of this chair before you begin riding. Start slowly, with easy, smooth strokes. If you are used to a different chair, you may use too much force and tip over. If you use too much force, damage to your chair, a fall, tip over or loss of control may occur and cause severe injury to the rider or others.

TO REDUCE THE RISK



WARNING

1. BEFORE riding, you should be trained in the safe use of this chair by your health care advisor.
2. Practice bending, reaching and transfers until you know the limit of your ability. Have someone help you until you know what can cause a fall or tip-over and how to avoid doing so.
3. Be aware that you must develop your own methods for safe use best suited to your level of function and ability.
4. NEVER try a new maneuver on your own until you are sure you can do it safely.
5. Get to know the areas where you plan to use your chair. Look for hazards and learn how to avoid them.
6. Use anti-tip tubes unless you are a skilled rider of this chair and are sure you are not at risk to tip over.

SAFETY CHECKLIST



WARNING

Before each use of your chair:

1. Make sure the chair rolls easily and that all parts work smoothly. Check for noise, vibration, or a change in ease of use. (They may indicate low tire pressure, loose fasteners, or damage to your chair).
2. Repair any problem. Your authorized supplier can help you find and correct the problem.

3. Check to see that both quick-release rear axles are locked. When locked, the axle button will "pop out" fully.

CHANGES AND ADJUSTMENTS



WARNING

1. If you modify or adjust this chair, it may increase the risk of a tip-over UNLESS you make other changes as well.
2. **Consult your authorized supplier BEFORE you modify or adjust your chair, or contact Future Mobility Healthcare.** We recommend that you use anti-tip tubes until you adapt to the change, and are sure you are not at risk to tip over.
4. Unauthorized modifications or use of parts not supplied or approved by Future Mobility Healthcare may change the chair structure.
- A. This will void the warranty and may cause a safety hazard.

GROUND TERRAIN



WARNING

1. Your chair is designed for use on firm, even surfaces such as concrete, asphalt and indoor floors and carpeting.
2. Do not operate your chair in sand, loose soil or over rough terrain. This may damage wheels or axles, or loosen fasteners of your chair.

CENTER OF GRAVITY



WARNING

The point where this chair will tip forward, back, or to the side depends on its center of gravity and stability. How your chair is set up, the options you select and the changes you make may affect the risk of a fall or tip-over.

1. The Most Important Adjustments Are:
 - a. The position of the rear wheels. The more you move the rear wheels forward, the more likely your chair will tip over backward.
 - b. The position of the carriage.
2. The Center Of Gravity Is Also Affected By:
 - a. A change in the set-up of your chair, including:
 - i. The seat height and seat angle.
 - ii. Backrest angle.
 - b. A change in your body position, posture or weight distribution.
 - c. Riding your chair on a ramp or slope.
 - d. The use of a back pack or other options, and the amount of added weight.

WHEELIES



WARNING

Because of the ability to adjust the center of gravity and changes in center of gravity that will result from operating the tilt in space feature of this chair, as a user, do not perform wheelies in this wheelchair. Doing a "wheelie" means: balancing on the rear wheels of your chair, while the front casters are in the air. It is dangerous to do a "wheelie" as a fall or tip-over may occur.

ROLLING BACKWARDS



Use extra care when you move your chair backward. Your chair is most stable when you propel yourself forward. You may lose control or tip over if one of the rear wheels hits an object and stops rolling.

1. Propel your chair slowly and smoothly.
2. If your chair has anti-tip tubes, make sure to lock them in place.
3. Stop often and check to be sure your path is clear.

REACHING OR LEANING



If you reach or lean it will affect the center of balance of your chair. This may cause you to fall or tip over. When in doubt, ask for help or use a device to extend your reach.

1. NEVER reach or lean if you must shift your weight sideways or rise up off the seat.
2. NEVER reach or lean if you must move forward in your seat to do so. Always keep your buttocks in contact with the backrest.
3. NEVER reach with both hands (you may not be able to catch yourself to prevent a fall if the chair tips).
4. NEVER reach or lean to the rear unless your chair has anti-tip tubes locked in place.
5. DO NOT reach or lean over the top of the seat back. This may damage one or both backrest tubes and cause you to fall.

6. If You Must Reach Or Lean:
 - a. Do not lock the rear wheels. This creates a tip point and makes a fall or tip-over more likely.
 - b. Do not put pressure on the footrests.
 - c. Move your chair as close as you can to the object you wish to reach.

RAMPS AND SLOPES



Riding on a slope, which includes a ramp or side hill, will change the center of balance of your chair. Your chair is less stable when it is at an angle. Anti-tip tubes may not prevent a fall or tip-over.

1. Do not use your chair on a slope steeper than 10%.
2. Always go as straight up and as straight down as you can. (Do not "cut the corner" on a slope or ramp.)
3. Do not turn or change direction on a slope.
4. Always stay in the CENTER of the ramp. Make sure ramp is wide enough that you are not at risk that a wheel may fall over the edge.
5. Do not stop on a steep slope. If you stop, you may lose control of your chair.
6. NEVER use rear wheel locks to try to slow or stop your chair. This is likely to cause your chair to veer out of control.
7. Beware Of:
 - a. Wet or slippery surfaces.
 - b. A change in grade on a slope (or a lip, bump or depression).

- c. A drop-off at the bottom of a slope. A drop-off of as small as 3/4 inch can stop a front caster and cause the chair to tip forward.

TRANSFERS



It is dangerous to transfer on your own. It requires good balance and agility. Be aware that there is a point during every transfer when the wheelchair seat is not below you. To Avoid A Fall:

1. Work with your health care advisor to learn safe methods.
 - a. Learn how to position your body and how to support yourself during a transfer.

4 ATTENDANT WARNINGS

TILTING THE WHEELCHAIR



In preparation to operate the tilt:

1. Always verify that the arms of the rider are stable on the armrests or within the armrests.
2. Always verify that the legs of the rider are stable on the footrest/ legrest.
3. Never place hands, feet or foreign objects into the tilt mechanism.
4. Never push or propel the chair with the seat tilted in a forward position.

- b. Have someone help you until you know how to do a safe transfer on your own.
2. Lock the rear wheels before you transfer. This keeps the rear wheels from rolling.
3. Make sure to keep pneumatic tires properly inflated. Low tire pressure may allow the rear wheel locks to slip.
4. Move your chair as close as you can to the seat you are transferring to. If possible, use a transfer board.
5. Rotate the front casters until they are as far forward as possible.
6. If you can, remove or swing footrests out of the way.
 - a. Make sure your feet do not catch in the space between the footrests.

Avoid putting weight on the footrests as this may cause the chair to tip.

5. Never add chair accessories that are not specifically designed for the wheelchair.
6. Never exceed a tilted position that aligns the backrest parallel to the ground.

DESCENDING A CURB



WARNING

Follow these steps to help a rider descend a curb or single step going BACKWARD:

1. Stay at the rear of the chair.
2. Several feet before you reach the edge of the curb or step, turn the chair around and pull it backward.

3. While looking over your shoulder, carefully step back until you are off the curb or stair and standing on the lower level.
4. Pull the chair toward you until the rear wheels reach the edge of the curb or step. Then allow the rear wheels to slowly roll down onto the lower level.
5. When the rear wheels are safely on the lower level, tilt the chair back to its balance point. This will lift the front casters off the curb or step.
6. Keep the chair in balance and take small steps backward.
7. Turn the chair around and gently lower front casters to the ground

CLIMBING A CURB



WARNING

Follow these steps to help the rider climb a curb or single step going FORWARD:

1. Stay behind the chair.
2. Face the curb and tilt the chair up on the rear wheels so that the front casters clear the curb or step.

3. Move forward, placing the front casters on the upper level as soon as you are sure they are past the edge.
4. Continue forward until the rear wheels contact the face of the curb or step. Lift and roll the rear wheels to the upper level.

DESCENDING STAIRS



WARNING

1. Use at least two attendants to move a chair and rider down stairs.
2. Move the chair and rider FORWARD down the stairs.
3. The person at the rear is in control. He or she tilts the chair to the balance point of the rear wheels and rolls it to the edge of the top step.
4. A second attendant stands on the third step from the top and grasps the hanger receiver or frontmost part of the seat rail. He or she lowers the chair one step at a time by letting the rear wheels roll over the stair edge.

The attendants move to the next stair down. Repeat for each stair, until you reach the landing.

5 COMPONENT WARNINGS

ANTI-TIP WHEELS



Anti-tip wheels can help keep your chair from tipping over backward in most normal conditions.

1. Future Mobility Healthcare Recommends Use Of Anti-Tip Tubes:
 - a. UNLESS you are a skilled rider of this chair and are sure you are not at risk to tip over.
 - b. Each time you modify or adjust your chair. The change may make it easier to tip backward. Use anti-tip tubes until you adapt to the change, and are sure you are not at risk to tip over.
2. When locked in place (in the "down" position) anti-tip tubes should be BETWEEN 1 1/2 and 2 inches off the ground.
 - a. If set too HIGH, they may not prevent a tip-over.
 - b. If set too LOW, they may "hang up" on obstacles you can expect in normal use. If this occurs, you may fall or your chair may tip over.
3. Keep Anti-Tip Tubes Locked In Place UNLESS:
 - a. You have an attendant, or
 - b. You have to climb or descend a curb, or overcome an obstacle, and can safely do so without them. At these times, make sure anti-tip tubes are up, out of the way.

ARMRESTS



Armrests will not bear the weight of this chair.

1. NEVER lift this chair by its armrests. They may come loose or break.
2. Lift this chair only by non-detachable parts of the main frame.

BACK CANES



Always keep fingers away from the locking mechanism located at the bottom of the back canes when folding the back down or pulling it back up.

FASTENERS



Many of the screws, bolts and nuts on this chair are special high-strength fasteners. Use of improper fasteners may cause your chair to fail.

1. ONLY use fasteners provided by an authorized supplier (or ones of the same type and strength, as indicated by the markings on the heads).
2. Over- or under-tightened fasteners may fail or cause damage to chair parts.

3. If bolts or screws become loose, tighten them as soon as you can.

FOOTRESTS



WARNING

Footrests will not bear the weight of this chair

1. At the lowest point, footrests should be AT LEAST 2 INCHES off the ground. If set too LOW, they may “hang up” on obstacles you can expect to find in normal use. This may cause the chair to stop suddenly and tip forward.
To Avoid A Trip Or Fall When You Transfer:
 - a. Make sure your feet do not “hang up” or get caught in the space between the footrests.
 - b. Avoid putting weight on the footrests, as the chair may tip forward.
3. NEVER lift this chair by the footrests. Footrests detach and will not bear the weight of this chair. Lift this chair only by non-detachable parts of the main frame.

POSITIONING BELTS



WARNING

Use positioning belts ONLY to help support the rider's posture. Improper use of these belts may cause severe injury to or death of the rider.

1. Make sure the rider cannot slide down in the wheelchair seat.

2. If this occurs, the rider may suffer chest compression or suffocate due to pressure from the belts.
3. The belts must be snug, but must not be so tight that they interfere with breathing. You should be able to slide your open hand, flat, between the belt and the rider.
4. A pelvic wedge or a similar device can help keep the rider from sliding down in the seat. Consult with the rider's doctor, nurse or therapist to find out if the rider needs such a device.
5. Use positioning belts only with a rider who can cooperate.
6. Make sure the rider can easily remove the belts in an emergency.
7. NEVER Use Positioning Belts:
 - a. As a patient restraint. A restraint requires a doctor's order.
 - b. On a rider who is comatose or agitated.
 - c. As a motor vehicle restraint. In an accident or sudden stop the rider may be thrown from the chair. Wheelchair seat belts will not prevent this, and further injury may result from the belts or straps.

QUICK-RELEASE AXLES



WARNING

1. Do not use this chair UNLESS you are sure that both quick-release rear axles are locked. An unlocked axle may come off during use and cause a fall.
2. An axle is not locked until the quick-release button pops out fully. An unlocked axle may come off during use, resulting in a fall, tip-over or loss of control and cause severe injury to the rider or others.

REAR WHEEL AXLES



WARNING

A change in set-up of the rear wheels will affect the center of balance of your chair.

1. The farther you move the rear axles FORWARD, the more likely it is that your chair will tip over backward.
2. Consult your doctor, nurse or therapist to find the best rear axle set-up for your chair. Do not change the set-up UNLESS you are sure you are not at risk to tip over.
3. Adjust the rear wheel locks after you make any change to the rear axles.
 - a. If you fail to do so, the locks may not work.
 - b. Make sure wheel locks are embedded in tires at least 1/8 inch when locked.

REAR WHEEL LOCKS



WARNING

Rear wheel locks are NOT designed to slow or stop a moving wheelchair. Use them only to keep the rear wheels from rolling when your chair is at a complete stop.

1. NEVER use rear wheel locks to try to slow or stop your chair when it is moving. Doing so may cause you to veer out of control.
2. To keep the rear wheels from rolling, always set both rear wheel locks when you transfer to or from your chair.

3. Low pressure in a rear tire may cause the wheel lock on that side to slip and may allow the wheel to turn when you do not expect it.
4. Make sure wheel locks are embed in tires at least 1/8 inch when locked. If you fail to do so, the locks may not wor

Features

FEATURES

- 3-48 degrees of tilt
- 6-36 degrees of recline (optional)
- Incredible low 13^{1/4} seat-to-floor height
- Orion back with 1" depth adjustability and Prism Ideal Cushion
- Aluminum seat pan
- Multi adjustable axle plate
- Removable rear wheels with stainless steel or plastic coated hand rims
- Arms heights: 9^{1/2"} – 14" (adjustable), Gel padding
- 70 degree pin style front rigging
- Aluminum or composite foot plates
- Adjustable rear anti tippers
- Padded lap tray
- Locking collar (optional)
- Heel loops
- Power tilt (optional upgraded version)

SPECIFICATIONS

- Seat Widths: 15" - 24"
- Seat Depths: 15" - 24"
- Overall Seat Width: Seat width + 9.5 including (hand rim to hand rim)
- Seat to floor height: 13^{1/4} – 20"
- Rear Wheel: 12", 20", 22" or 24" composite urethane
- Orion back (16", 18", 20" H). Low or tall push canes with stroller bars
- Adjustable back angle: -7°, 0°, 7°, 14°, 21°
- Arm Style: Full length adjustable height t-style (gel or vinyl), full length adjustable height pin release (t-style), full length adjustable height flip back (gel or vinyl)
- Front Rigging: Pin style, swing-away, dual swing-away, elevating leg rests or dual elevating leg rests.
- Weight capacity: 350lbs (159 kg)
- Product weight: 65lbs (including seating system)
- Frame Material: Steel
- Frame Colours: Black or Silver

Safety Inspection Checklist

Initial adjustments should be made to suit your personal body structure needs and preference. Thereafter follow these maintenance procedures:

Item	Initially	Weekly	Monthly	Periodically
GENERAL				
Wheelchair rolls straight (no excessive drag or pull to one side)	X		X	
FRAME AND CROSSING TUBES				
Inspect for loose or missing hardware	X			X
Inspect for bent frame or cross-tubes	X			X
WHEEL LOCKS				
Do not interfere with tires when rolling	X		X	
Pivot points free of wear and looseness	X		X	
Wheel locks easy to engage	X			X
Wheel locks prevent chair from moving when engaged	X	X		
SEAT AND BACK				
Inspect for rips or sagging	X			X
Inspect for loose or broken hardware	X		X	
Inspect cane and hand grips for wear/looseness	X		X	
TIRES				
Inspect for flat spots, cracks and wear Caution: as with any vehicle, the wheels and tires should be	X	X		X

checked periodically for cracks and wear and should be replaced.				
<u>REAR WHEELS</u> If equipped, quick-release axles lock properly No excessive side movement or binding when lifted and spun Inspect for cracked, bent or broken spokes	X X X	X X	X	X
<u>HANDRIMS</u> Inspect for signs of rough edges or peeling	X			X
<u>FRONT CASTERS/FORKS</u> Inspect caster fork assembly for proper tension by spinning caster; caster should come to a gradual stop Adjust bearing system if wheel wobbles or binds to a stop. Ensure wheel bearings are clean and free of moisture. Check stem caster journal and lock nut for tightness Inspect casters for cracks and wear Inspect for cracked, bent or broken spokes	X X X X X	X X X X X	X X	X X X X
<u>CLEANING</u> Clean upholstery and armrests	X			X

Troubleshooting

Chair Veers Right/Left	Wheels Drift	Sluggish Turn or Performance	Caster Flutter	Squeaks and Rattles	Looseness in Chair	Solutions
X	X	X	X	X	X	Check for loose nuts and bolts
X			X			Check angle adjustable caster assembly
X	X					Check that rear wheels are equally spaced away from seat frame.

Labels

ORION II

WARNING

DO NOT OPERATE WITHOUT
THE ANTI-TIP MECHANISM
IN PLACE

WEIGHT CAPACITY

350 LBS. (159 kgs)
REFER TO OWNER'S MANUAL

CAUTION

MOVING THE REAR AXLE TO THE
FORWARD POSITION MAY
DECREASE THE STABILITY OF THE
WHEEL CHAIR

6 T-Style Knob Release Arm Rests

Installing and removing T-Style arm rests (Figure 1)

Installing and Removing T-Style Armrest

1. Push armrest into arm socket until lock is engaged into slot.
2. For removal, push and hold release lever (`A'), while lifting armrest from arm socket.

Frame Adjustment Position

1. Remove armrest from the chair.
2. Remove the three inside bolts holding the arm socket to the seat frame (`B').
3. Move the arm socket to the forward mounting position (`C') and replace the three bolts (`B').
4. Re-install the armrest in the arm socket.

Arm Height Adjustment

1. Loosen knob (`D').
2. Lift armrest until desired position is acquired (ranges from 9 1/2" – 14" in 1/2" increments).
3. "Re-tighten" knob (`D').

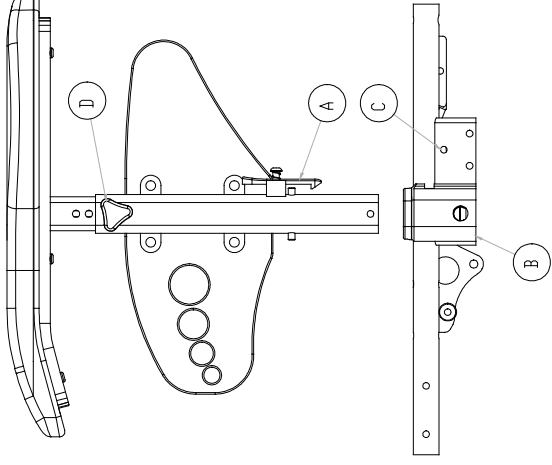

Figure 1

7 Flip-up Arm Rests

Engaging/Disengaging and Adjusting Flip-Up Style Arm Rest (Figure 2)

Engaging and Disengaging Flip-Up Style Armrest

1. To engage, push armrest into arm socket until release lever ('A') is engaged into slot.
2. For flip-up, push and hold release lever ('A'), while lifting armrest from arm socket.

Arm Height Adjustment

1. Loosen knob ('B').
2. Lift armrest until desired position is acquired (ranges from 9 1/2" – 14" in 1/2" increments).
3. "Re-tighten" knob ('B')

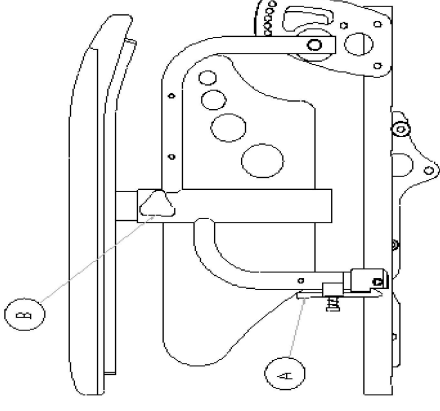

Figure 2

8 T-Style Pin Release Arm Rests

Adjusting and Installing T-Style Pin Release Armrests (Figure 3)

Installing and Removing T-Style Armrest

1. Push armrest into arm socket until lock is engaged into slot.
2. For removal, push and hold release lever while lifting armrest from arm socket.

Arm Height Adjustment

1. Swing out the height adjustment latch lever to disengage the holding pin.
2. Lift armrest until desired position is acquired (ranges from 9"– 13" in ½" increments).
3. Swing in the height adjustment latch lever to engage the holding pin.
4. Repeat this procedure for the opposite T-style arm assembly.

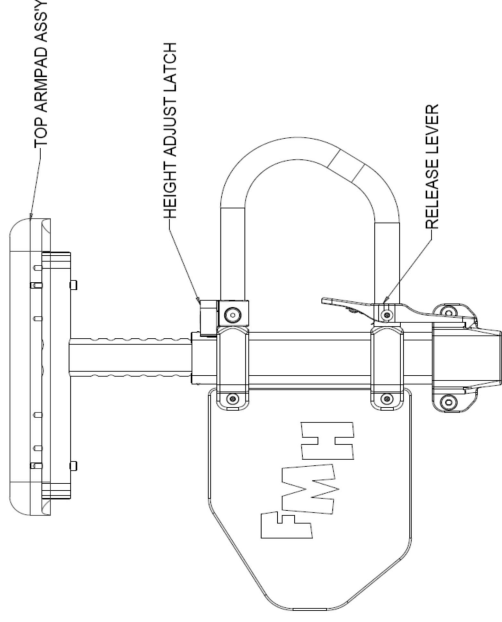

Figure 3

9 Pin Style Swingaway Leg Rest

Installing and adjusting pin style leg rests and foot plate (Figure 4)

Installing and Removing Pin-Style Legrests

1. Position pin style swing-away legrest tabs onto leg rest hanger pins ensuring footplate is facing inward.
2. Swing the legrest inwards such that the legrest latch 'clicks' into place.
3. For removal, push the legrest latch to release the legrest from the locked position and swing outwards. Lift the legrest assembly off the legrest hanger pins.

Footplate Adjustment

1. Remove bolt which holds the footrest extension tube in place. Slide footrest extension tube up or down to desired height.
2. "Re-tighten" bolt.

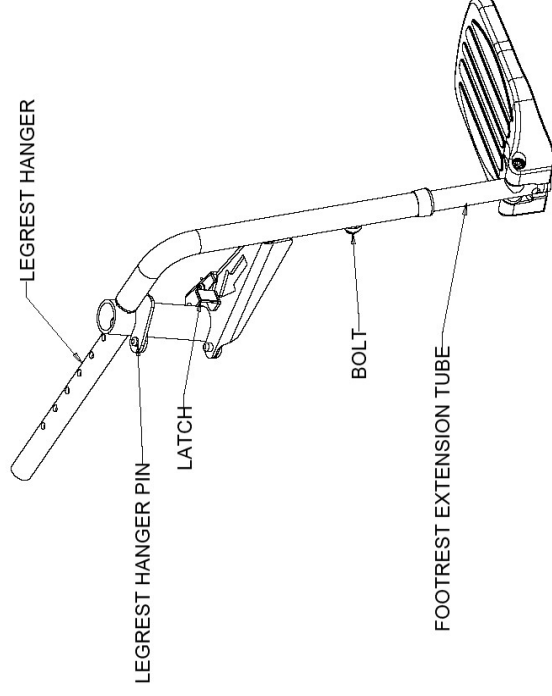

Figure 4

10 Center Pivot Swingaway Legrest

Installing and removing center pivot swingaway leg rests and foot plate (Figure 5)

Installing and Removing Center Pivot Swingaway Legrests

1. Position center pivot swing-away leg rest onto hanger insuring pivot plug sits flush onto hanger tube.
2. Swing the leg rest inwards such that the swingaway latch assembly 'clicks' into place onto the u-bolt.
3. To remove leg rest pull handle releasing the latch mechanism from the u-bolt and swing leg rest outward.

Footplate Length Adjustment

1. Remove bolt which holds the footrest extension tube in place. Slide footrest extension tube up or down to desired height.
2. "Re-install" bolt.

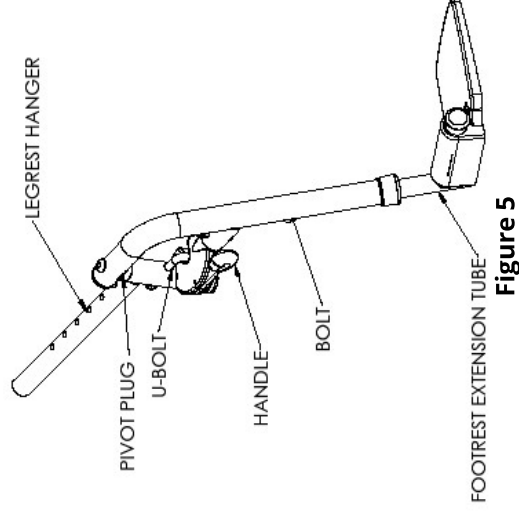

Figure 5

1.1 Center Pivot Dual Swingaway Legrest

Installing and removing center pivot swingaway leg rests and foot plate (Figure 6)

Installing And Removing Center Pivot Dual Swingaway Legrests

1. Position center pivot dual swing-away leg rest onto hanger insuring pivot plug sits flush onto hanger tube.
2. Swing the leg rest such that the dual swingaway latch assembly 'clicks' into place onto the dual swingaway base
3. To remove leg rest pull up on handle releasing the dual swingaway latch mechanism and swing leg rest outward or inwards.

Footplate Length Adjustment

1. Remove bolt which holds the footrest extension tube in place. Slide footrest extension tube up or down to desired height.
2. "Re-install" bolt.

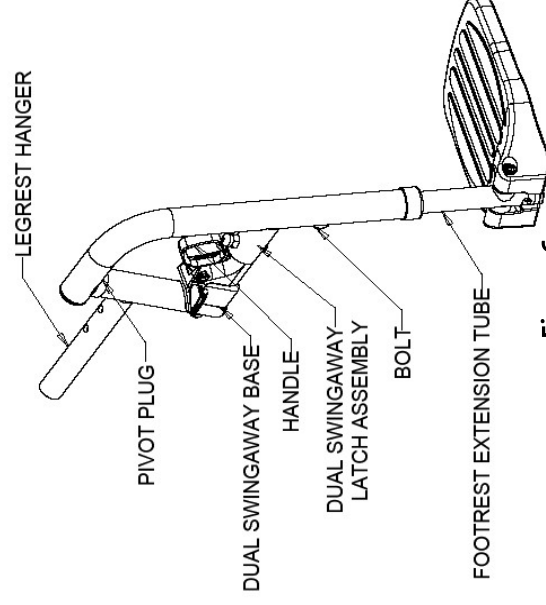

Figure 6

12 Center Pivot Swingaway Elevating Legrest

Installing and adjusting leg rests and foot plate (Figure 7, Figure 8)

Installing and Removing Center Pivot Swingaway Elevating Legrests

1. Insert the elevating leg rest adjustable hanger into the opening of the seat frame tube.
2. Position the elevating leg rest swing-away section onto the hanger by dropping the pivot plug into the open end of the hanger vertical tube.
3. Swing inwards until the swingaway latch engages and locks into the "U - Bolt".
4. Slide the assembly horizontally until the pivot of the leg rest is inline "horizontally" with the user's knee pivot.
5. Loosen the front bolts on the elevating leg rest hanger and slide the vertical post until the pivot of the leg rest is inline "vertically" with the user's knee pivot.

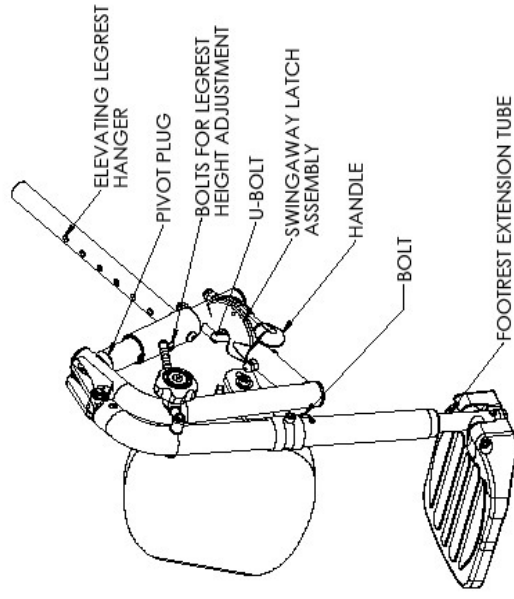

Figure 7

6. Re-tighten bolts on hanger side.
470 REV.04 REV DATE: 12/17/2018

7. Adjust footplate and calf pad position to fit user's leg length.
8. To remove elevating leg rest pull handle releasing the latch mechanism from the u-bolt and swing leg rest outward.

Footplate Length Adjustment

1. Remove bolt which holds the footrest extension tube in place. Slide footrest extension tube up or down to desired height.
2. "Re-install" bolt.

Elevating Leg Rest Operation (Refer To Figure 8)

1. To adjust the angle of the elevating leg rest, turn the handle knob counter-clockwise to disengage from the index rod.
2. Lift the leg rest to the desired angle.
3. Re-tighten the handle knob such that the leg rest arm remains firmly in position.

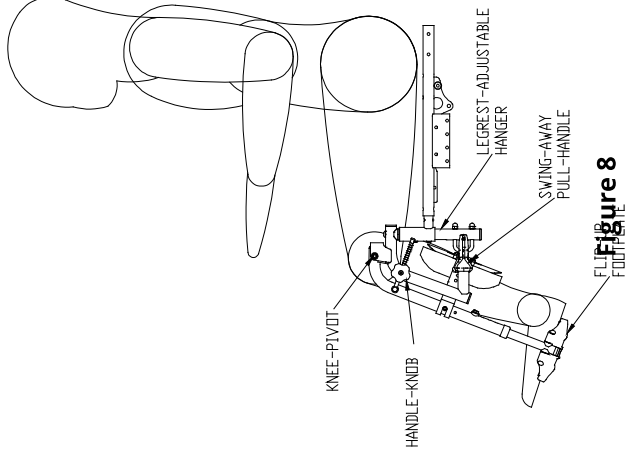

Figure 8

13 Fixed Back/Cane Stroller Bar

Adjusting back angle (Figure 9, Figure 10)

To Adjust Angle

Manufacturer's setting is 90 degrees, with each hole representing 7 degree increments (holes range from 83 degrees to 111 degrees).

1. Remove nut and screw from the top side of the outer and inner mounting plates.
2. Move fixed back cane to desired angle and insert nuts and bolts making sure the covered spacers are in place.

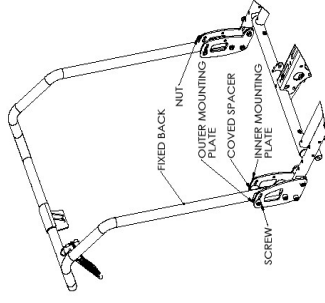

Figure 9

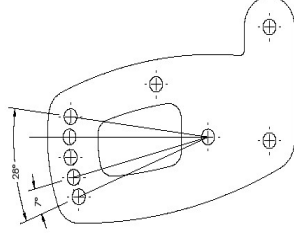

Figure 10

14 Fold Down Back Cane/Stroller Bar

Adjusting angle and folding down back (Figure 11, Figure 12)

To Adjust Angle

Manufacturer's setting is 90 degrees, with each hole representing 7 degree increments (holes range from 83 degrees to 111 degrees). Please note for fixed cane and stroller only angle can be adjusted via locking and unlocking bolts.

1. Remove nut and bolt from the top side of the outer and inner mounting plates.
2. Move fold down back cane to desired angle and insert nuts and bolts making sure the covered spacers are in place.

To Fold Down Back

1. Push up knob on the left side to disengage pin in the locked position.
2. Push and hold up the knob on the right side to release back post forward.
3. To return back to an upright position, lift back posts up ensuring right side locks into place and pulling left knob out and down.

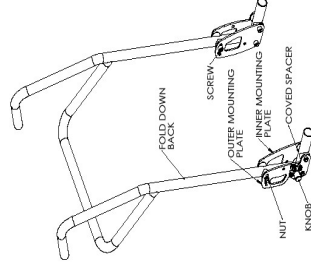

Figure 11

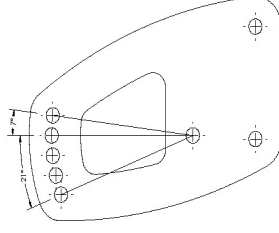

Figure 12

15 Recline Back Cane Stroller/Bar

Reclining the Back (Figure 13, Figure 14)

To Recline Stroller/Cane And Cane Bar

1. To recline the Orion II depress the lever as depicted in **Error! Reference source not found.** and depress the pushbar in a downward motion to allow the recline.
2. **Error! Reference source not found.** shows a pushbar stroller on an Orion II model without the levers.
3. There are two levers on the handle pushbar. One handle is for tilt of the full wheel chair and the other allows for a recline of the back seat.
4. **WARNING:** If Orion II comes without cylinder assembly attached then make sure to install the cylinder on the frame before depressing the levers on the handle.



Figure 13

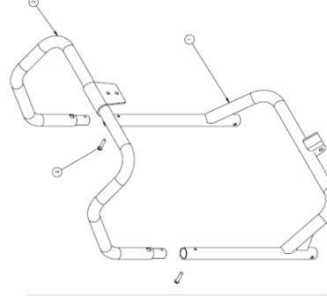

Figure 14

16 Hinged Stroller Bar (Angle Adjustable)

Adjusting angle of stroller bar (Figure 15)

To Adjust Angle of Stroller Bar

1. Place each hand on the push bar hinge assembly button.
2. Push the bottom inwards to activate the hinge assembly mechanism and rotate the stroller bar to the desired angle for the attendant.
3. Release the buttons to lock the hinge assembly mechanism in place.

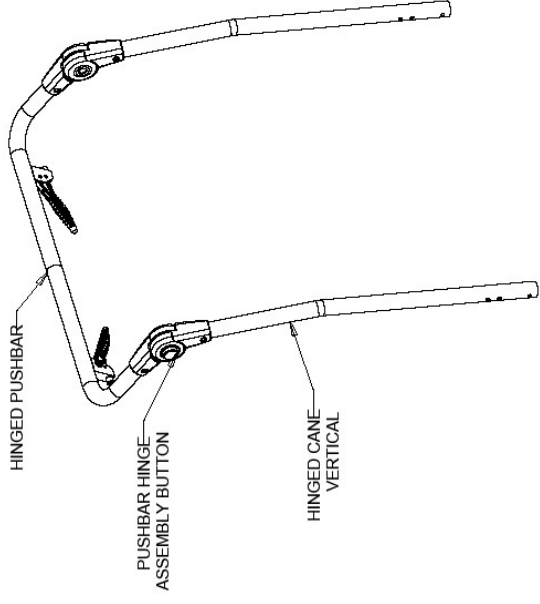

Figure 15

17 Recline Cylinder Installation

Installing recline cylinder (Figure 16)

Please follow the bill of materials listed below when installing the recline back, recline cylinder and mounting brackets.

Assemble recline mount bracket #14 & #15 onto seat frame and fasten with hardware items #3, #4, #6.

1. Assemble recline back cane #2 onto recline mount brackets and fasten with hardware items #4, #5, #6.
2. Assemble stabilis actuator and gas cylinder assembly (#9, #13) onto seat frame bracket using hardware item #11. Assemble gas cylinder (#9) onto recline back cane using hardware items # 7,#8, #10, #12.

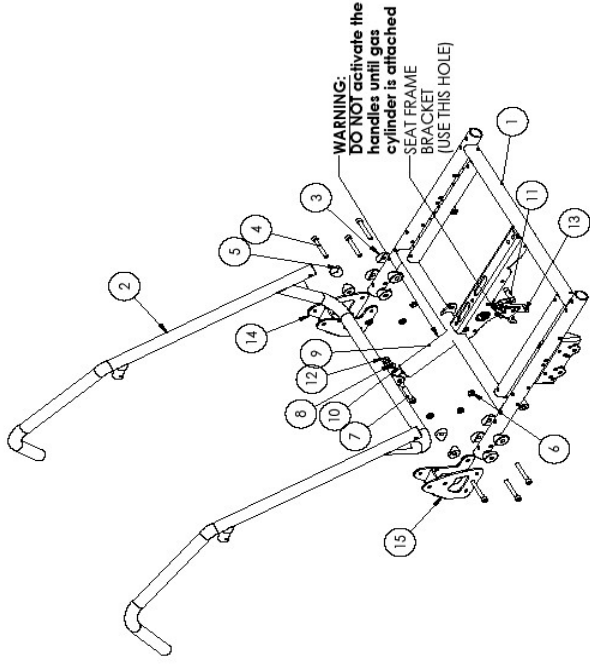

Figure 16

18 Rear Wheel Positioning

Installing and positioning rear wheels (Figure 17-19)

WARNING

After **ANY** adjustments, repair or service and **BEFORE** use, make sure all attaching hardware is tightened securely – otherwise injury or damage may occur.

REMOVING/INSTALLING THE REAR WHEELS

WARNING

If changing the size of the rear wheel or a change in the seat-to-floor height is desired, this procedure MUST be performed by a qualified technician.

1. Push in the detent pin of the quick-release axle (with wheel) and pull the axle out through the opening in the center of the rear wheel and shaft spacer.
2. Push in the detent pin of the quick-release axle again and pull the axle out of the rear wheel.

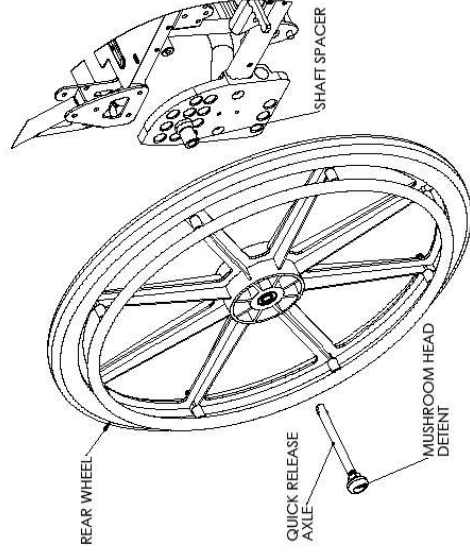

Figure 17

3. To reinstall the rear wheel onto the wheelchair, reverse steps 1 to 2.
4. Repeat this procedure for the other rear wheel assembly if required.
5. If using the Push-to-Lock or Pull-to-Lock mechanism ensure the wheel locks properly. See the section **ADJUSTING THE WHEEL LOCKS**.

WARNING

1. Make sure the detent pin and locking pins of the quick-release axle are fully released **BEFORE** operating the wheelchair.
2. The locking pins **MUST** be protruding past the inside of the rear wheel axle bushing for a positive lock.
3. Keep locking pins clean.
4. Future Mobility Healthcare Inc. recommends inserting quick-release axles with the detent pin to the inside of the wheelchair to prevent accidental release during contact activities.

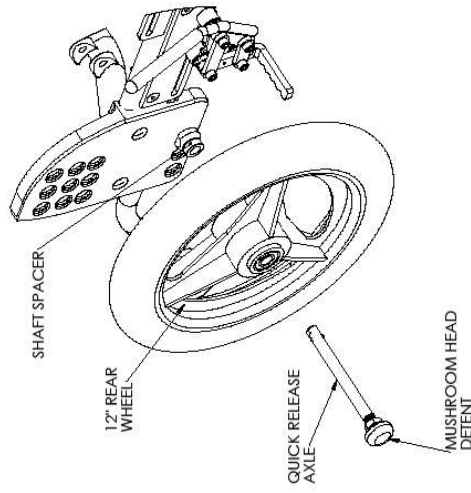

Figure 18

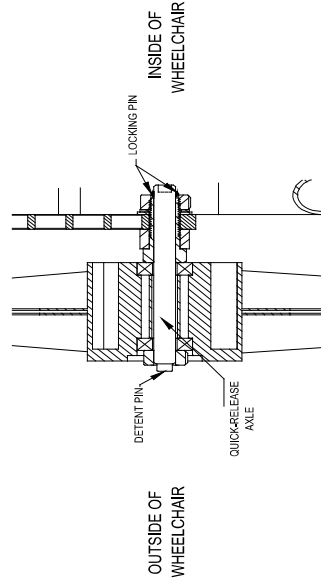

Figure 19

19 Wheel Locks

Operating wheel locks (Figure 20, Figure 21)

WARNING

DO NOT attempt to stop a moving wheelchair with the wheel locks. **WHEEL LOCKS ARE NOT BRAKES** – otherwise injury or damage may occur.

1. Ensure the wheelchair is not moving before engaging the wheel locks.
2. Perform one (1) of the following:
 - a. Push-to-Lock – to engage, push the wheel lock handle ('A') forward
 - b. Pull-to-Lock – to engage, pull the wheel lock handle ('A') backward
3. Disengage the wheel locks by reversing STEP 2.

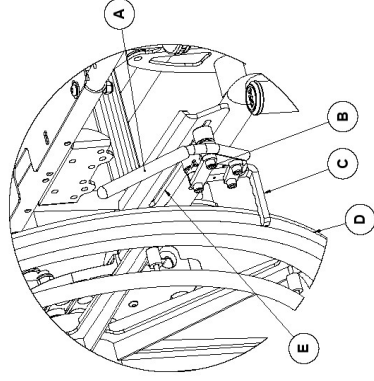

Figure 20

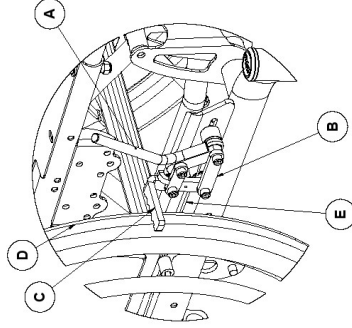

Figure 21

20 Adjusting the Patient Operated Wheel Locks

See [\(Figure 20, Figure 21\)](#)

1. Disengage the wheel locks ('A').
2. Loosen the two (2) locknuts which hold the wheel lock link 1 ('B') shown in the above figure that secure the wheel lock to the wheelchair frame.
3. Reposition the wheel lock along the brake mount plate ('E') so that when engaged, the wheel lock brake shoe ('C') embeds the tire ('D') 1/8" (3/16" for pneumatic tires) and **HOLDS** the occupied wheelchair in place when pushed.
4. Securely tighten the two locknuts securing the wheel lock to the wheelchair frame.
5. Engage the wheel lock.
6. Measure the distance the wheel lock is embedded into the tire
7. Repeat STEPS 1 to 6 until the wheel lock brake shoe embeds the tire and **HOLDS** the occupied wheelchair in place when pushed.
8. Engage both wheel locks and ensure the occupied wheelchair is held in place when pushed.

21 Front Casters

Installing and removing forks and casters (Figure 22-25)

WARNING

After **ANY** adjustments, repair or service and **BEFORE** use, make sure all attaching hardware is tightened securely – otherwise injury or damage may occur.

Installing/Replacing Front Casters and Forks

Replacing/Installing Front Casters – Refer To Error! Reference source not found.

Note: This procedure can be performed if replacing the exact same size front caster.

1. Remove the nut ('A'), bolt ('B') and spacers ('C') (not shown) which secure the caster to the fork assembly ('D').
2. Remove the front caster ('E').
3. Slide in the new 4, 5, 6, 7 or 8 inch front caster into the space between the fork.
4. Tighten the nut, bolt and spacers to secure the caster into place.
5. Repeat this procedure for the other front caster wheel assembly if required.

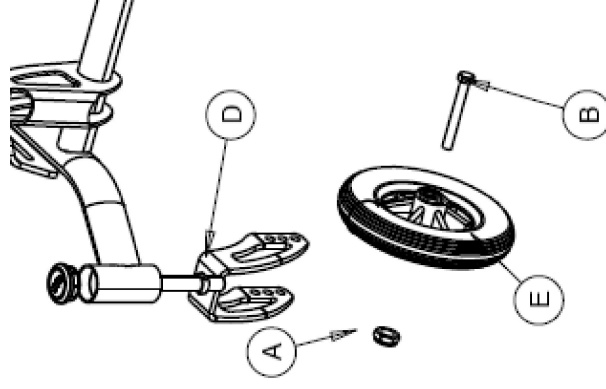
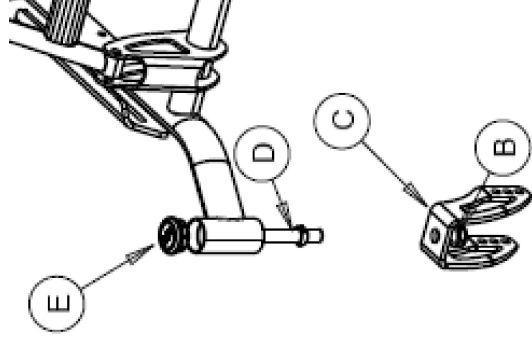

Figure 22

6. To properly tighten caster journal system and guard against flutter, perform the following check:
 - a. Tip back of wheelchair to floor
 - b. Pivot both forks and casters to top of their arc simultaneously.
 - c. Let casters drop to bottom of arc (wheels should swing once to one-side, then immediately rest in a straight downward position).
 - d. Adjust locknuts according to freedom of caster swing.
7. Test wheelchair for maneuverability.
8. Re-adjust locknuts if necessary and repeat STEPS 6 to 7 until correct.
9. Snap dust cover over the locknut and stem.



Replacing/Installing Front Forks – Refer To

Figure 23

1. Remove the locknut and the cap (E) which secures the caster stem bolt (D) to the caster housing right under (E).
2. Drop the front caster and fork assembly out of the caster housing.
3. Remove the locknut (B) which secures the caster stem to the fork (C)

4. Follow REPLACING/INSTALLING FRONT CASTERS guide in this section to remove the front caster from the fork assembly.
5. Place the caster in the new fork and assemble with the caster nut and bolt and spacer.
6. Secure the new fork and caster assembly in place by using the locknut and caster stem bolt.
7. Follow steps 5 to 9 of REPLACING/INSTALLING FRONT CASTERS guide to properly install the new fork assembly and prevent fluttering.

Seat to Floor

1. Follow the values in the tables in **Error! Reference source not found.** to achieve the desired height.
2. Ensure that no weight is on the wheelchair while performing the operations
3. Ensure after changing the seat to floor height that the wheelchair is still operational and that no wheel flutter or instability occurs.

FRONT STF	REAR WHEEL	AXEL POS. SUPERLOW
13.25	20"	2
13.25	16"	2
14.5	20"	1
14.5	16"	3
15.0	20"	2
15.5	22"	1
15.5	12"	4
16.0	24"	1
16.0	20"	2
16.0	20"	3
16.0	12"	4
16.5	24"	1
16.5	22"	2
16.5	24"	1
17.0	24"	2
17.0	22"	3
18.0	16"	4
18.0	24"	3
19.0	24"	3
20.0	24"	3

* 1" RISER BLOCK REQUIRED

** 2" RISER BLOCK REQUIRED

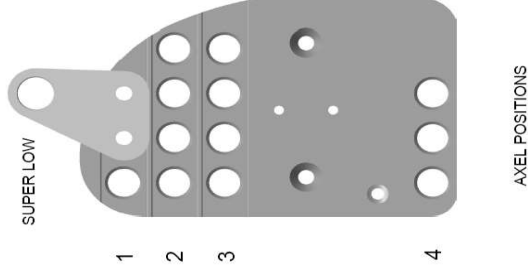

Figure 24

4. The wheel should be inserted in the middle hole on the axle plate to achieve the seat to floor heights listed below. In case the user requires more stability the wheel can be inserted in the hole furthest to the back of the chair and if the user requires more maneuverability then the wheel can be inserted in the hole closest to the front of the chair.

FRONT STF	CASTER	FORK HOLE	STEM LENGTH
13.25	4"	1	X-SHORT
14.5	5"	1	SHORT
15.0	5"	2	SHORT
15.5	5"	3	SHORT
16.0	6"	3	SHORT
16.5	7"	3	SHORT
16.0	5"	3	LONG
16.5	6"	3	LONG
17.0	7"	3	LONG
17.0	8"	3	LONG
18.0	8"	4	LONG
19.0	9"	4	LONG
20.0	8"	4	LONG

* 1" RISER BLOCK REQUIRED

** 2" RISER BLOCK REQUIRED

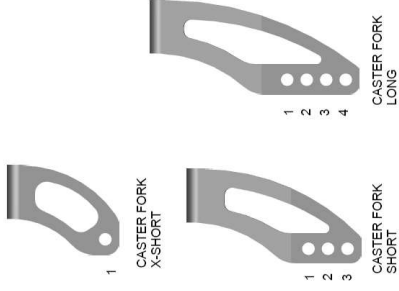

Figure 25

22 Anti-Tippers

Installing/ adjusting anti-tippers (Figure 26, Figure 27)

WARNING

After **ANY** adjustments, repair or service and **BEFORE** use, make sure all attaching hardware is tightened securely – otherwise injury or damage may occur.

Installing/Adjusting the Anti-Tippers

WARNING

Anti-tippers are specific to the different seat-to floor angles and/or seat-to-floor heights. Refer to the chart in this section of the manual for correct usage and adjustment. If these requirements **CANNOT** be achieved; **DO NOT** use the wheelchair. Contact a qualified technician. If changing the seat-to-floor height with or without a change to seat-to-floor angle, the correct anti-tippers **MUST** be used to maintain a 1 ½" to 2" ground clearance.

Seat-to-floor angle of 3 degrees to 6 degrees: if so equipped, anti-tippers **MUST** be attached at all times. In as much as the anti-tippers are an option on this wheelchair (you may order with or without the

40

Orion II

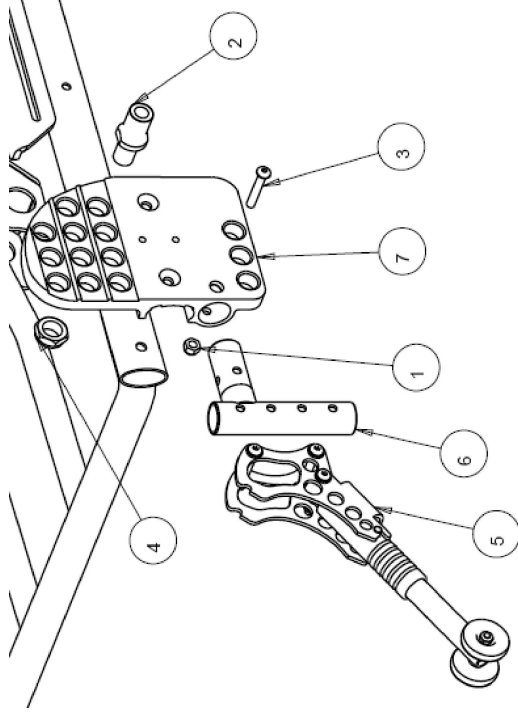

Figure 26

470 REV.04 REV DATE: 12/17/2018

anti-tippers), Future Mobility Healthcare Inc. strongly recommends ordering the anti-tippers as a safeguard for the wheelchair user.

Anti-tippers **MUST** be fully engaged and snap buttons fully protruding out of adjustment holes.

Ensure both anti-tippers are adjusted to the same mounting hole.

Installing Anti-Tippers

1. Insert anti-tipper (5) into the tube weldment (6) as show in Fig 26 making sure to align the two holes of the anti-tipper to the tube weldment.
2. Screw two bolts to secure the anti-tipper (5) to the tube weldment (6).
3. Insert the tube weldment into the hole of the axle plate (7).
4. While inserting the tube into the axle plate align the two holes on the axle plate and the tube.
5. Once the holes are aligned, screw bolt (3) and nut (1) through the holes to secure anti-tipper to the wheel chair.
6. Once properly assembled anti-tippers are ready to use.

470 REV.04 REV DATE: 12/17/2018

Orion II

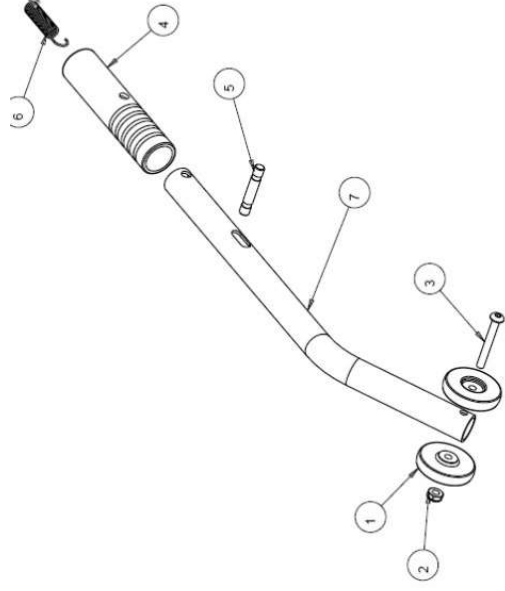

Figure 27

7. Refer to FLIPPING THE ANTI-TIPPERS below for flip up and flip down instructions.
8. The height of the anti-tippers can be changed by aligning the two holes on the tube weldment and the anti-tipper. Refer to item (6) in Fig 26.
9. If you are having difficulty attaching the anti-tipping assembly to the wheel chair please call a certified health care technician for more help.

Note: A 1 ½ "to 2" clearance between the bottom of the anti-tipper wheels and the ground/floor MUST be maintained at all times.

Flipping the Anti-Tippers

1. Press the snap button on the anti-tip assembly and adjust the anti-tip slide tube up or down until a 1 ½"to 2" clearance from the ground is achieved.
2. Check to make sure that the snap buttons are fully engaged in the adjustment holes.

23 Cable Adjustment Procedure

Adjusting recline cable (Figure 28, Figure 29)

1. Insert the cable (upper) completely into the release lever housing.
2. Feed the longer lower cable through the cable bracket as shown.
3. Insert a 7/32 retaining clip onto the groove on the adapter cable to fix the Mech. Lock to the cable.
4. Push the cable holder down to compress the spring and place the ball end of the cable through the slotted arm of the cable holder and into the groove of the ball lock cylinder as shown in **Error! Reference source not found.**
5. Release the cable holder to keep the ball end cable in place as shown in **Error! Reference source not found**
6. To adjust the cable, loosen both lower lock nuts and move the adaptor to shorten or lengthen the cable adjustment length as needed. If this length is decreased too much slippage of the lock may occur. This must be avoided.
7. Actuate the release lever to assure that the mechanical lock operates correctly and does not slip without actuating the release lever.

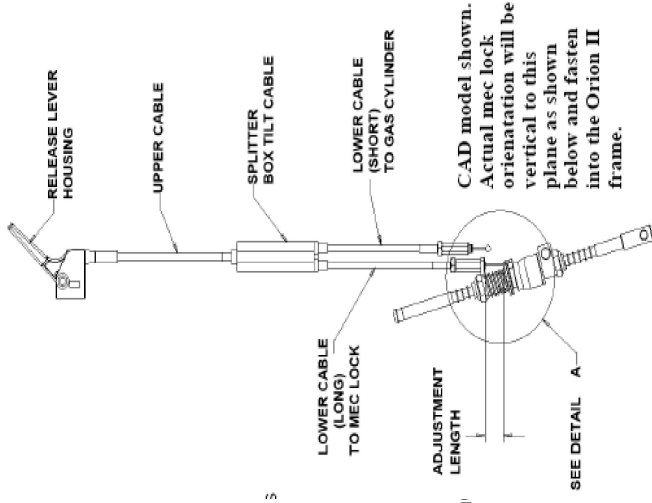

Figure 28

8. After the proper adjustment is obtained, tighten the lower lock nuts on the adapter cable. Use the minimum amount of torque necessary to lock it into position – (1/4 turn of wrench is maximum).

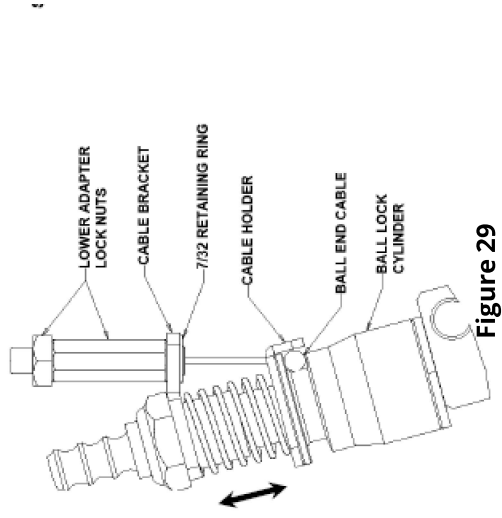

Figure 29

24 MAINTENANCE

GENERAL MAINTENANCE

1. Maintaining your chair in good working order will keep it functioning properly and help extend the working life of the chair.
 2. Clean your chair often.
 3. Make sure to replace worn or damaged parts as soon as possible to prevent future injury.
 4. It is recommended to have any work done on the chair by an authorized dealer.
 5. Follow the safety inspection checklist chart for optimum performance.
 6. We recommend that once a year to have a complete inspection, service and safety check of your chair by an authorized dealer.
3. Contact Future Mobility directly by telephone, fax, or e-mail to obtain information regarding repair at Future Mobility facilities.
 4. You will be asked by the Customer Service Representative for the serial number that is affixed to the wheelchair.
 5. If any of the following conditions are observed, the wheelchair must be serviced at Future Mobility:
 - a. Any part of the frame is cracked or broken
 - b. Any weld is cracked or broken
 6. For safe and secure shipping, the wheelchair must be placed in a suitable carton, or fastened to a pallet, to ensure it does not sustain damage during shipping. Contact Future Mobility to receive specific instructions for packaging and shipping your wheelchair. Alternatively, Future Mobility may arrange for pick-up.



Failing to follow these recommendations could lead to possible injury.

SERVICE AND REPAIR

1. Please contact the dealership or supplier from where the wheelchair was purchased for service and moderate repair.
2. In some circumstances, it may be necessary to return your wheelchair to Future Mobility for repairs.

CLEANING YOUR CHAIR

1. **Cleaning your Seat and Back**
 - a. Remove the outer and inner cover if required and hand wash with a small amount of detergent.
 - b. Hang to dry the covers, do not machine dry or wring out.
 - c. Use multipurpose disinfectant to spray seat, scrub with soft brush if needed.
 - d. Test an inconspicuous area first for color-fastness.

- e. **DO NOT USE HOT AIR FOR DRYING.**
- f. **DO NOT IMMERSE** the cushion or back foam in water or cleaning solution.
- g. Some color leeching from the cover onto the foam is normal and cannot be washed out.

2. Paint Finish

- a. Clean the painted surfaces with mild soap at least once a month
- b. Protect the paint with a coat of non-abrasive auto wax every three months.

3. Axles and Pivot joints

- a. Clean around axles and moving parts WEEKLY with a slightly damp (not wet) cloth.
- b. Wipe off or blow away any dust or dirt on axles or moving parts.



WARNING

**Do not use abrasive powders or scouring pads on painted surfaces.
Do not ever submerge chair in water.
Do not use cleaning products without consulting the products' instructions and taking appropriate precautions for human exposure to chemicals.**

25 Warranty

LIFETIME

Wheelchair Frame and Cross- Brace

1. Future Mobility Healthcare Inc. guarantees the frame and cross brace against defects in material and workmanship for life or for as long as the original purchaser owns the chair.
2. This warranty is void if:
 - a. The chair is shown to be abused.
 - b. The chair is not maintained as recommended in the owner's manual.
 - c. The chair is transferred to a different person from the original owner.

FOR TWO (2) YEARS

Wheelchair Back and Cushions (Excluding Upholstery)

1. Future Mobility Healthcare Inc. guarantees the back and cushion to be free of defects in material and workmanship for two years.

Wheelchair Components Excluding Limitations

1. Future Mobility Healthcare Inc. guarantees the wheelchair components to be free of defects in material and workmanship for two years.

FOR (90) DAYS

Cushion and Back Upholstery

1. Future Mobility Healthcare Inc. guarantees the wheelchair cushion and back upholstery to be free of defects in material and workmanship for 90 days.

LIMITATIONS

- a. Tires, Caster Wheels, Push-Handles and Grips.
 - b. Damage from negligence, accident, misuse, or from improper installation or repair.
 - c. Products modified without written consent from FMHI.
 - d. Damage from exceeding the wheelchair weight limit.
2. This warranty is VOID if the original chair serial number label is removed or altered.
 3. This warranty is not transferable and only applies to the first consumer purchase of this wheelchair through an authorized Future Mobility Dealer.

WARRANTY PROCEDURES

1. If within this warranty period the product shall be proven to be defective, such product shall be repaired or replaced, at FMHI discretion.
2. FMHI's sole obligation and your exclusive remedy under this warranty shall be limited to the repair and/or replacement of the product or its parts.
3. This warranty does not include any labor or shipping charges incurred in replacement part installation or repair of any product.
4. For warranty service, please contact the dealer from whom you purchased your FMHI product. In the event you do not receive satisfactory warranty service, please write directly to FMHI.
5. DO NOT return products to FMHI without our prior consent. The defective unit or parts must be returned for warranty inspection within thirty (30) days of the return authorization date. (FMHI will issue a return authorization number). Please prepay all shipping charges; C.O.D. shipments will be refused.

The foregoing warranty is exclusive and in lieu of all other expressed warranties. It shall not extend beyond the duration of the expressed warranty provided herein and the remedy for violations of any implied warranty shall be limited to repair or replacement of the defective product pursuant to the terms contained herein. FMHI shall not be liable for any consequential or incidental damages whatsoever

Cut below this line #

Warranty Registration Form

To validate your Future Mobility Health Care warranty, please complete the below form and return it the address at the end of this form. Visit online at www.futuremobility.ca for more Future Mobility Products.

Name: _____
Street Address: _____
City/Country/Postal Code: _____
Telephone: _____
Purchased Date: _____
Purchased From (Dealer Name & Address): _____
Product Purchased: _____
Serial Number: _____

Print and Mail it to:
Future Mobility Healthcare Products
6750 Professional Court
Mississauga, Ontario, L4V 1X6
Fax: 905-671-3377

CANADA

Future Mobility Healthcare Inc.

6750 Professional Court

Mississauga, ON L4V 1X6

Ph: 905 671-1661 – Toll Free: 1 888 737-4011

Fax: 905 671-3377

Toll Free Fax: 1-866-670-3377

e-mail: customerservice@futureamobility.ca

www.futureamobility.ca



FUTURE MOBILITY

INNOVATIVE SEATING AND HOME MOBILITY SOLUTIONS

USA

Future Mobility Products US LLC

1 Buffalo River Place

Buffalo, NY, 14210

Tel: 716-783-9130 – Toll Free 1-855-938-

898873

Fax: 716-783-9236

Toll Free Fax: 1-866-670-3377

e-mail: customerservice@futureamobility.ca

www.futureamobility.ca



FUTURE MOBILITY

PRODUCTS