

*PaceSaver*<sup>®</sup>  
Scooters

# Owner's Manual



*Eclipse™ Series*



*Espree™ Series*



*Plus III™ Series*

**(Must Be Given to User)**







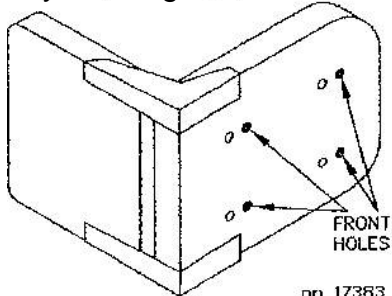

**READ** this entire Owner's Manual **BEFORE**  
you operate your new scooter!

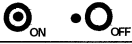
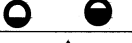
See inside front cover for special instructions.

# "SPECIAL OPTION" WARNINGS

SEAT MOUNT INFORMATION
<p><b>CAUTION:</b> Some seats have a second set of mounting holes.</p> <p>The front hole location can provide 1" extra leg room.</p> <p>If the front set of holes is used, it will reduce the maximum incline rating of the vehicle by 3 degrees.</p> <p>See owners manual for max. incline specifications of your particular model based on your weight.</p>
 <p style="text-align: right;">pn 17383</p>

## EXPLANATION OF INTERNATIONAL SYMBOLS USED WITH THIS EQUIPMENT

SYMBOL	EXPLANATION
	INFORMATIONAL - ON - OFF
	INFORMATIONAL - EMPTY - FULL
	INFORMATIONAL - READ MANUAL - CAN BE ASSOCIATED WITH WARNINGS
	INFORMATIONAL - READ MANUAL - CAN BE ASSOCIATED WITH WARNINGS
	INFORMATIONAL - DO NOT OPEN CONTROLLER BOX
	ELECTRICAL - MAINS SWITCH/ CIRCUIT BREAKER
	ELECTRICAL - PERSONAL SHOCK HAZARD
	ELECTRICAL - BATTERY - OBSERVE POLARITY
	ELECTRICAL - MOTOR
	ELECTRICAL - CLASS B EQUIPMENT

# Table of Contents

THIS MANUAL COVERS MANY DIFFERENT STYLES OF *PaceSaver*<sup>®</sup> SCOOTERS.  
BE SURE AND FIND THE INFORMATION THAT PERTAINS TO YOUR STYLE.

<b>Introduction</b>	<b>2</b>
<b>Important Safety Information</b>	<b>3</b>
<i>PaceSaver</i> Specifications	<b>8</b>
<b>Getting On and Off The <i>PaceSaver</i></b>	<b>12</b>
<b>Operating the <i>PaceSaver</i></b>	<b>13</b>
<b>Your First Ride</b>	<b>16</b>
<b>The <i>PaceSaver</i> Braking Systems</b>	<b>17</b>
<b>Brake Disengage Mechanism</b>	<b>18</b>
<b>Seat Assembly Operation</b>	<b>19</b>
<b>Disassembly &amp; Assembly</b>	<b>22</b>
<b>Charging Your Batteries</b>	<b>24</b>
<b>General Care &amp; Maintenance Section</b>	<b>33</b>
<b>Trouble-Shooting</b>	<b>36</b>
<b>Commonly Asked Questions and Possible Answers</b>	<b>38</b>
<b>Addendums</b>	<b>41</b>

# *PaceSaver*<sup>®</sup> OWNERS MANUAL

## Introduction

Congratulations on your choice of a *PaceSaver* Scooter! It is a dependable vehicle built for power and performance. The *PaceSaver's* rear wheel drive system will outperform front wheel drive styles on any surface, indoors or out. It has excellent handling characteristics and its compact design makes it agile in even the smallest places. The *PaceSaver's* patented separation makes it easy to assemble and disassemble. It's easy to operate controls give you more of what you are looking for in a scooter.

But it is important that you understand what your scooter is, and what it is not. *PaceSaver* scooters are designed to provide safe, reliable transportation to older or mildly physically handicapped individuals who have difficulty in getting around. It will safely take you everywhere the specifications indicate as long as you follow the simple safety guidelines shown on the next few pages.

*PaceSavers* (like all scooters) are not all terrain vehicles that you can use out in the fields to drag brush around or climb steep hills. They were not meant to go hunting in, or transport you thru hazardous environments. They also are not designed for the severely handicapped individual who is trying to avoid a power wheelchair. You must have good stability, motor control and above all else, good common sense to use our scooter or any other brand. If you feel that you cannot safely operate this vehicle at all times you should not use a scooter!

**Important** Please read the entire manual carefully before attempting to drive your new *PaceSaver*.

Remember to read all service recommendations outlined in this manual to achieve trouble free, safe and enjoyable operation of your *PaceSaver*. Failure to follow the recommended service procedures will damage your scooter and such damage is not covered under warranty. Contact your dealer if you have questions after reading this manual.

**Leisure-Lift<sup>®</sup>, Inc. specifically disclaims responsibility for any bodily injuries or property damage which may occur during any use which does not comply with applicable Federal, State, or Local laws and ordinances or methods recommended in this manual. If in doubt about your ability to operate your *PaceSaver*, consult your doctor.**

**NOTE: MODIFYING AND/OR TAMPERING IN ANY UNAUTHORIZED MANNER WITH THE SCOOTER WILL VOID THE WARRANTY AND MAY CAUSE THE SCOOTER TO MALFUNCTION, EXPOSING YOU TO PHYSICAL HARM.**

**ATTENTION: This manual covers several styles of the *PaceSaver*. While most of the information is the same for all styles, make sure that the specifications you are reading applies to the particular styles you have. If you are unsure of the styles *PaceSaver* you have, contact your dealer.**

**Your *PaceSaver* is a vehicle which provides independence and freedom to people with limited mobility. Driver error can cause injury to the driver and to other people. Please use common sense, courtesy, and obey the following guidelines for vehicle operation.**

**READ THIS ENTIRE MANUAL  
BEFORE DRIVING THIS VEHICLE.**

### **Safety Guidelines**

**Always** turn the key switch to the OFF position when stopped or when getting off or on the *PaceSaver*. This keeps you from accidentally hitting the throttle and causing an accident. For persons with limited lower body strength, or persons who make slide transfers and may forget to turn the key switch off, we recommend the use of the delta tiller option. Delta tillers can limit access to controls for people with limited hand flexibility - Fingertip controls may be required.

**Use extra caution** when riding your *PaceSaver* off of the pavement or on rough, uneven surfaces or tipping and injury will result. If you intend to operate your *PaceSaver* on rough, uneven surfaces, and are willing to sacrifice indoor maneuverability, consider our Wide Tire Option (not available on certain styles) for increased stability.

**Do not exceed** the incline specifications for the style of *PaceSaver* that you own or it will become unstable and tipping will result. Persons with limited ability to protect themselves (like persons paralyzed on one side) should use protective equipment such as bicycle headgear. The specification chart in your manual will indicate the maximum incline for your particular style.

**Keep your feet** on the floorpan while riding the *PaceSaver* to avoid hitting them on objects as you drive.

**Lock the seat** assembly before operating the *PaceSaver* to prevent yourself from falling from the seat while moving.

**Remember,** The *PaceSaver* is built to carry a single person. Do not carry passengers under any circumstances or accidents and bodily injury will occur.

**Always** go straight up or down curb cuts or a ditch, not at an angle. You want the front wheels and the rear wheels to climb up or go down together, not one at a time. Not doing this will result in the steering tiller violently swinging from side to side (as a car would in a ditch) or the scooters overturning. Also approach curb access ramps the same way, straight on, not at an angle. **NEVER** attempt to go up or down a regular height curb or tipping and personal injury will result!

**Driving** the *PaceSaver* in busy streets, busy parking lots, or in crowded shopping malls can be dangerous for you or other people as you may be struck by a vehicle or you might strike a pedestrian. Use caution in congested areas at all times. **WARNING**, Driving at night or around large vehicles is dangerous as it makes it difficult for drivers to see you. Being struck or crushed by vehicles can result in death.

**Lean forward** a slight amount when traveling up an incline.

**NEVER** leave your scooter exposed to the elements. This includes storage outside or carrying the scooter on an outside car-lift during periods of high moisture (mist, rain, snow, etc.) or any other inclement weather (dust or sand storms, etc.). Severe damage or malfunction can result.

**Use caution** when driving off of a curb or raised surface. The act of dropping off the edge subjects the scooter to extreme forces that can damage the frame and other components. This type of damage is not covered under warranty.

**Disconnect the batteries** before performing any maintenance beneath the seat or on the tiller. This avoids both the possibility of injuries due to shock or accidental movement of the scooter. Make sure that the batteries are secure when you are using the scooter.

**Follow the directions** of your doctor and/or pharmacist at all times. Do not drive the *PaceSaver* while taking medications that affect your reflexes or mental judgment, as your driving will be impaired and accidents may result. Do not drink alcohol and operate this or any other vehicle.

**The following are important things to help you drive the *PaceSaver* in the safest possible manner. Please take note of each one.**

**WARNING: DO NOT** engage in the following activities with your PaceSaver or serious injury may result.

**DO NOT** remain seated on your PaceSaver while it is being loaded into a vehicle using anything other than a special scooter lift.

**DO NOT** use the PaceSaver as a seat in a moving vehicle. As of this date, the Department of Transportation has not approved any tie down system for transportation of a user while in a scooter in a moving vehicle of any type. The rider must be seated in a regular automotive seat and restrained by an approved automobile safety belt. The rider must be warned that there is a many times greater likelihood of severe injury or death in the event of an accident if they are not in the provided automotive seat and restraint system. The following attachment points are provided for the sole purpose of securing the mobility device without the rider. The scooter and batteries **MUST** be independently and properly restrained or stored in a separate compartment so as to prevent it from causing injury in an accident.

## **CONVENIENT TIE DOWN POINTS**

The following is a list of convenient locations that the straps from a 4 point securement system could be anchored on PaceSaver products. These products have not been crash tested and certified as crash worthy using these locations.

### **3 WHEELED SCOOTERS**

Back anchor points - Place a strap around the lower portion of each armrest support.

Front anchor points - Place a strap around the front axle bolt between the wheel and fork on each side of the wheel.

### **4 WHEELED SCOOTERS**

Back anchor points - Place a strap around the lower portion of each armrest support.

Front anchor points - Place a strap around the front crossbar axle mount on each side.

**DO NOT** ride the *PaceSaver* with the brake manually disengaged at anytime.

**DO NOT** drive the *PaceSaver* diagonally across inclines, turn sharp or make turns at or near full throttle at any time. Doing this will result in overturning and serious personal injury can result.

**DO NOT** drive the *PaceSaver* with the seat assembly higher than necessary as tipping and serious injury may result. The lower the seat, the better your stability.

**DO NOT** drive the *PaceSaver* with under-inflated tires as this increases the possibility of tipping and injury. Your stability and efficiency (power and range) are also greatly affected. Filled tires are available if you are unable to check your tire pressure.

**DO NOT** stop on any incline to rest or dismount. Although the electric brake will stop and hold you, it is best to stop in level, flat areas where there is no possibility of rolling or tipping the unit.

**DO NOT** drive on inclines greater than the rating for your style *PaceSaver* or tipping will result. Refer to the Specification Sheet and Ramp Incline Chart elsewhere in this manual.

**DO NOT** allow the *PaceSaver* controls to become wet. Never wash off the scooter using a hose or a stream of water, drive through standing water or ride in the rain. Possible loss of control and/or electronic damage will occur. Do not attempt to ride a scooter that has been soaked until it has had a chance to dry thoroughly.

**DO NOT** leave the *PaceSaver* where it is exposed to high temperatures (a car trunk, etc.) or to poor weather conditions such as rain or snow or freezing conditions as damage to the unit will occur.

**DO NOT** disassemble any wheel at any time while still inflated. The pressure may blow wheel rims apart while you are loosening them.



**DO NOT** ride the unit near stairs, ledges or in any other potentially dangerous situation.

**DO NOT** ride the scooter over power cords, oxygen lines, hoses or any other material that could become entangled in the wheels or get caught in the drive mechanism of the scooter or while connected to equipment off of the scooter, as serious injury may result.



Persons having disabilities which limit their ability to remain erect without assistance, (stroke patients, severe muscular diseases, etc.) should carefully evaluate whether they should operate a scooter at all. If they decide, with the advise of their physician or another advisor, that they are capable of safely operating a scooter, they should consider the use of a bicycle helmet or pads when operating a scooter. These articles would help protect them should they find themselves in a hazardous situation where they could tip over because of their lack of balance. The controller can also be programmed to fit your requirements.

**DIFFERENT STYLES OF SCOOTERS HAVE DIFFERENT INCLINE CLIMBING ABILITIES. CAREFULLY STUDY THE CHART TO SEE THE CORRECT SPECIFICATIONS FOR YOUR UNIT. DO NOT EXCEED THE SPECIFICATIONS OF THE SCOOTER STYLE YOU PURCHASED!**

<b>RAMPS, STEEP TERRAIN, CURBS, STEPS &amp; RIDER TRANSFER</b>	
	<p><b>DO NOT</b> drive on ramps or steep terrain greater than 12 degrees.</p> <p><b>DO NOT</b> attempt to drive your scooter backward down any step, curb or any other obstacle.</p>
	<p><b>DO NOT</b> drive near raised surfaces, unprotected ledges, and/or drop-offs (curbs, porches, stairs, ect.).</p>
	<p><b>USE CURB CUTS</b> whenever possible to go up and down curbs.</p> <p><b>Always drive straight up/down or perpendicular to curbs or curb cuts. Never traverse at an angle.</b></p>
<p><b>RIDER TRANSFER:</b> Refer to the section of the owners manual titled 'Getting On and Off the PaceSaver'.</p>	

# *Plus III* Series Specifications

Spec's subject to slight variations	<b>Plus III™ Junior 10"/9"</b>	<b>Plus III™ 9" Premier</b>	<b>Plus III™ 10" Premier</b>	<b>Plus III™ Titan</b>
<u>OVERALL LENGTH</u>	42"	45.5"	45.5"	45.5"
<u>OVERALL WIDTH</u>	24" / 23.5"	23.5"	24"	24."
<u>WEIGHT</u>	-----	-----	-----	-----
REAR DRIVE UNIT	45 lbs.	42.5 lbs.	43.3 lbs.	43.3 lbs.
BASE AND TILLER	37 lbs.	34.5 lbs.	35 lbs.	35 lbs.
SEAT SECTION	25 lbs.	23.75 lbs.	23.75 lbs.	24.5 lbs.
BATTERY & CASE SHROUD	25 lbs. ea.	25 lbs. ea.	25 lbs. ea.	25 lbs. ea.
	-----	-----	-----	-----
<u>MAXIMUM SPEED (M.P.H.)</u>	<b>5.25 / 4.3</b>	<b>4.3</b>	<b>5.25</b>	<b>5.25</b>
<u>RANGE</u> *(On one charge) (MILES)	14 (U1 Batt)	14 (U1 Batt)	14 (U1 Batt)	21 / 13
Group 22 Batt. / U1 Batt.	-----	-----	-----	-----
<u>GROUND CLEARANCE</u>	-----	-----	-----	-----
Below Transaxle	2.5" / 2"	2"	2.5"	2.5"
Below Frame	4.5" / 4.25"	4.25"	4.5"	4.5"
<u>TURNING RADIUS</u>	36"	39"	39"	39"
<u>TIRE SIZE</u>	-----	-----	-----	-----
FRONT	2.5" X 9"	2.5" X 9"	3" X 9"	3" X 9"
REAR	10" / 9"	3" X 9"	3" X 10"	3" X 10"
<u>SEAT DIMENSIONS</u>	-----	-----	-----	-----
WIDTH	18"	18"	18"	18"
DEPTH	18"	18"	18"	18"
BACK HEIGHT	16"	20"	20"	20"
<u>SEAT HEIGHT</u> (from floorpan)	16.75" TO 18.75"	16.75" TO 18.75"	16.75" TO 18.75"	16.75" TO 18.75"
W/POWER SEAT	18" TO 23"	18" TO 23"	18" TO 23"	18" TO 23"
<u>ELECTRONIC BRAKES</u>	YES	YES	YES	YES
(Regenerative & Dynamic)				
<u>ADD. SAFETY BRAKING</u>	YES	YES	YES	YES
("Posi-Lock" Disk Brake)				
<u>DRIVE TYPE</u>	Transaxle	Transaxle	Transaxle	<b>Transaxle</b>
<u>MOTOR SIZE</u>	<b>1 1/4 HP</b>	<b>1 1/4 HP</b>	<b>1 1/4 HP</b>	<b>1 1/4 HP</b>
<u>INCLINE STABILITY**</u>	16% Grade	22% Grade	22% Grade	22% Grade
<u>STRUCTURAL CAPACITY***</u>	<b>300 LBS.</b>	<b>300 LBS.</b>	<b>300 LBS.</b>	<b>350 LBS.</b>

**9 degrees = 16%**  
**10 degrees = 17.6%**  
**12 degrees = 22%**

### Do Not Exceed The Maximum Incline Stability For Your Style Scooter!

\* *Range tested to the US Ansi/Resna Standard with product maximum weight capacity. Customer's range may vary according to customer's weight, terrain type, battery condition and/or tire condition.*

\*\* *Incline stability is determined per US Ansi/Resna Dynamic Stability test 8.2. Stability increases by leaning forward or seat not in highest position.*

\*\*\* *Approved for use by riders weighing up to the maximum weight capacity shown in addition to approved Leisure Lift accessories and options available for that model.*

# *Plus III Cont. & Eclipse Series Specifications*

Spec's subject to slight variations	<b>Plus III™ Atlas</b>	<b>Eclipse™ Premier</b>	<b>Eclipse™ Atlas</b>
<u>OVERALL LENGTH</u>	45.5"	49.75"	49.75"
<u>OVERALL WIDTH</u>	26.5"	24"	26.5"
<u>WEIGHT</u>	-----	-----	-----
REAR DRIVE UNIT	43.3 lbs.	41 lbs.	41 lbs.
BASE AND TILLER	45 lbs.	59 lbs.	61 lbs.
SEAT SECTION	29.75 lbs.	24.5 lbs.	29.75 lbs.
BATTERY & CASE	25 lbs. ea.	25 lbs. ea.	25 lbs. ea.
SHROUD	-----	3.5 lbs.	3.5 lbs.
<u>MAXIMUM SPEED (M.P.H.)</u>	<b>5.25</b>	<b>5.25</b>	<b>5.25</b>
<u>RANGE*(On one charge) (MILES)</u>	18 / 12	21 / 12	16 / 9
Group 22 Batt. / U1 Batt.	-----	-----	-----
<u>GROUND CLEARANCE</u>	-----	-----	-----
Below Transaxle	2.5"	2.5"	2.5"
Below Frame	4.5"	4.5"	4.5"
<u>TURNING RADIUS</u>	39"	56.5"	56.5"
<u>TIRE SIZE</u>	-----	-----	-----
FRONT	3" X 9"	3" X 10"	3" X 10"
REAR	3" X 10"	3" X 10"	3" X 10"
<u>SEAT DIMENSIONS</u>	-----	-----	-----
WIDTH	21"	18"	21"
DEPTH	21"	18"	21"
BACK HEIGHT	22"	20"	22"
<u>SEAT HEIGHT (from floorpan)</u>	16.75" TO 18.75"	16.75" TO 18.75"	16.75" TO 18.75"
W/POWER SEAT	18" TO 23"	18" TO 23"	18" TO 23"
<u>ELECTRONIC BRAKES</u> (Regenerative & Dynamic)	YES	YES	YES
<u>ADD. SAFETY BRAKING</u> ("Posi-Lock" Disk Brake)	YES	YES	YES
<u>DRIVE TYPE</u>	<b>Transaxle</b>	<b>Transaxle</b>	<b>Transaxle</b>
<u>MOTOR SIZE</u>	<b>1 1/4 HP</b>	<b>1 1/4 HP</b>	<b>1 1/4 HP</b>
<u>INCLINE STABILITY**</u>	17.6% Grade	22% Grade	17.6% Grade
<u>STRUCTURAL CAPACITY***</u>	<b>450 LBS.</b>	<b>350 LBS.</b>	<b>450 LBS.</b>

**9 degrees = 16%**  
**10 degrees = 17.6%**  
**12 degrees = 22%**

### **Do Not Exceed The Maximum Incline Stability For Your Style Scooter!**

\* *Range tested to the US Ansi/Resna Standard with product maximum weight capacity. Customer's range may vary according to customer's weight, terrain type, battery condition and/or tire condition.*

\*\* *Incline stability is determined per US Ansi/Resna Dynamic Stability test 8.2. Stability increases by leaning forward or seat not in highest position.*

\*\*\* *Approved for use by riders weighing up to the maximum weight capacity shown in addition to approved Leisure Lift accessories and options available for that model.*

# Espree Series Specifications

Spec's subject to slight variations	Espree™ 9" Premier	Espree™ 10" Premier	Espree™ Titan	Espree™ Atlas
<u>OVERALL LENGTH</u>	45.5"	45.5"	45.5"	45.5"
<u>OVERALL WIDTH</u>	23.5"	24"	24"	26.5"
<u>WEIGHT</u>	-----	-----	-----	-----
REAR DRIVE UNIT	40 lbs.	41 lbs.	41 lbs.	41 lbs.
BASE AND TILLER	36.5 lbs.	37 lbs.	37 lbs.	45 lbs.
SEAT SECTION	24.5 lbs.	24.5 lbs.	24.5 lbs.	29.75 lbs.
BATTERY & CASE	25 lbs. ea.	25 lbs. ea.	25 lbs. ea.	25 lbs. ea.
SHROUD	3.5 lbs.	3.5 lbs.	3.5 lbs.	3.5 lbs.
<u>MAXIMUM SPEED (M.P.H.)</u>	<b>4.3</b>	<b>5.25</b>	<b>5.25</b>	<b>5.25</b>
<u>RANGE</u> *(On one charge) (MILES)	23 / 14	23 / 14	21 / 13	18 / 12
Group 22 Batt. / U1 Batt.	-----	-----	-----	-----
<u>GROUND CLEARANCE</u>	-----	-----	-----	-----
Below Transaxle	2"	2.5"	2.5"	2.5"
Below Frame	4.25"	4.5"	4.5"	4.5"
<u>TURNING RADIUS</u>	39"	39"	39"	39"
<u>TIRE SIZE</u>	-----	-----	-----	-----
FRONT	2.5" X 9"	3" X 9"	3" X 9"	3" X 9"
REAR	3" X 9"	3" X 10"	3" X 10"	3" X 10"
<u>SEAT DIMENSIONS</u>	-----	-----	-----	-----
WIDTH	18"	18"	18"	21"
DEPTH	18"	18"	18"	21"
BACK HEIGHT	20"	20"	20"	22"
<u>SEAT HEIGHT</u> (from floorpan)	16.75" TO 18.75"	16.75" TO 18.75"	16.75" TO 18.75"	16.75" TO 18.75"
W/POWER SEAT	18" TO 23"	18" TO 23"	18" TO 23"	18" TO 23"
<u>ELECTRONIC BRAKES</u> (Regenerative & Dynamic)	YES	YES	YES	YES
<u>ADD. SAFETY BRAKING</u> ("Posi-Lock" Disk Brake)	YES	YES	YES	YES
<u>DRIVE TYPE</u>	Transaxle	Transaxle	<b>Transaxle</b>	<b>Transaxle</b>
<u>MOTOR SIZE</u>	<b>1 1/4 HP</b>	<b>1 1/4 HP</b>	<b>1 1/4 HP</b>	<b>1 1/4 HP</b>
<u>INCLINE STABILITY**</u>	22% GRADE	22% GRADE	22% GRADE	17.6% GRADE
<u>STRUCTURAL CAPACITY***</u>	<b>300 LBS.</b>	<b>300 LBS.</b>	<b>350 LBS.</b>	<b>450 LBS.</b>

**8 degrees = 14%**  
**10 degrees = 17.6%**  
**12 degrees = 22%**

### Do Not Exceed The Maximum Incline Stability For Your Style Scooter!

\* *Range tested to the US Ansi/Resna Standard with product maximum weight capacity. Customer's range may vary according to customer's weight, terrain type, battery condition and/or tire condition.*

\*\* *Incline stability is determined per US Ansi/Resna Dynamic Stability test 8.2. Stability increases by leaning forward or seat not in highest position.*

\*\*\* *Approved for use by riders weighing up to the maximum weight capacity shown in addition to approved Leisure Lift accessories and options available for that model.*

# *Espree 500 and Eclipse 500 Series Specifications*

Spec's subject to slight variations	Espree™ Atlas 500	Eclipse™ Atlas 500
<u>OVERALL LENGTH</u>	45.5"	49.75"
<u>OVERALL WIDTH</u>	26.5"	26.5"
<u>WEIGHT</u>	-----	-----
REAR DRIVE UNIT	41 lbs.	41 lbs.
BASE AND TILLER	45 lbs.	61 lbs.
SEAT SECTION	29.75 lbs.	29.75 lbs.
BATTERY & CASE	25 lbs. ea.	25 lbs. ea.
SHROUD	3.5 lbs.	3.5 lbs.
<u>MAXIMUM SPEED (M.P.H.)</u>	<b>5.25</b>	<b>5.25</b>
<u>RANGE*(On one charge) (MILES)</u>	17 / 11	15 / 9
Group 22 Batt. / U1 Batt.	-----	-----
<u>GROUND CLEARANCE</u>	-----	-----
Below Transaxle	2.5"	2.5"
Below Frame	4.5"	4.5"
<u>TURNING RADIUS</u>	39"	56.5"
<u>TIRE SIZE</u>	-----	-----
FRONT	3" X 9"	3" X 10"
REAR	3" X 10"	3" X 10"
<u>SEAT DIMENSIONS</u>	-----	-----
WIDTH	21"	21"
DEPTH	21"	21"
BACK HEIGHT	22"	22"
<u>SEAT HEIGHT (from floorpan)</u>	16.75" TO 18.75"	16.75" TO 18.75"
W/POWER SEAT	18" TO 23"	18" TO 23"
<u>ELECTRONIC BRAKES</u> (Regenerative & Dynamic)	YES	YES
<u>ADD. SAFETY BRAKING</u> ("Posi-Lock" Disk Brake)	YES	YES
<u>DRIVE TYPE</u>	Transaxle	Transaxle
<u>MOTOR SIZE</u>	<b>1 1/4 HP</b>	<b>1 1/4 HP</b>
<u>INCLINE STABILITY**</u>	14% GRADE	14% GRADE
<u>STRUCTURAL CAPACITY***</u>	<b>500 LBS.</b>	<b>500 LBS.</b>

**8 degrees = 14%**  
**10 degrees = 17.6%**  
**12 degrees = 22%**

### **Do Not Exceed The Maximum Incline Stability For Your Style Scooter!**

- \* *Range tested to the US Ansi/Resna Standard with product maximum weight capacity. Customer's range may vary according to customer's weight, terrain type, battery condition and/or tire condition.*
- \*\* *Incline stability is determined per US Ansi/Resna Dynamic Stability test 8.2. Stability increases by leaning forward or seat not in highest position.*
- \*\*\* *Approved for use by riders weighing up to the maximum weight capacity shown in addition to approved Leisure Lift accessories and options available for that model.*

## Getting On and Off the *PaceSaver*

### The following is a recommended method for getting on your *PaceSaver*.

1. The scooter should be stopped on a flat, level surface with the key in the OFF position.
2. Rotate the unlocked seat assembly to one side & re-lock.
3. Position yourself squarely in front of the seat and lower yourself into the seat using the armrests if necessary.
4. Unlock the seat and rotate toward the front of the scooter. Lock the seat in position by pushing down on the seat lock lever firmly. The seat will not move when locked correctly. Lower the tiller to a comfortable angle. **Never use the tiller as a support while getting on and off the scooter.**
5. When seated comfortably, you can drive the *PaceSaver*.

### The method for getting off is the reverse procedure.

1. Turn the key switch OFF when stopped.
2. Raise the tiller out of your way.
3. Unlock the seat lock and rotate the seat to one side, then re-lock it.
4. Stand up carefully.

## WARNING

Keep the key in the OFF position at all times when stopped or when getting on or off the scooter. Sudden accidental movement of the scooter will be avoided with the key in the OFF position.

Tipping can occur if you get on the *PaceSaver* in a manner other than recommended. Tipping can be avoided by keeping your weight away from the outer edges until seated. If you step into the scooter, step near the center of the floorpan, not near the edge. Tipping can also occur if you turn the steering tiller sharply while traveling at or near full throttle.

## Operating the PaceSaver

All controls for *PaceSaver* operation are located on the tiller mounted panel (See FIGURE 1). Become familiar with all controls in the following section.

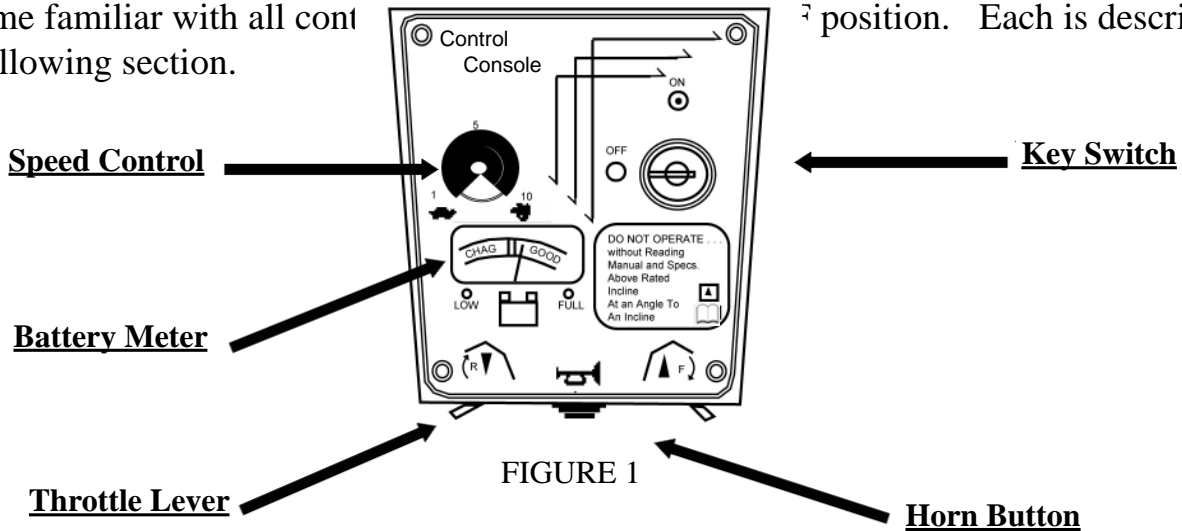

Faceplates may vary in appearance.

### Control Console

**1. ON and OFF KEY SWITCH.** Turning the key to the ON position turns the power on. In this position, the key cannot be removed. **NOTE:** There is a 3 second diagnostic delay when key is turned on. Turning to the OFF position turns the power off. The key should always be in the OFF position when you are not driving, or when getting off or on the scooter. The key can only be removed when in the OFF (stopped) position.

**SAFETY INFORMATION** - The key switch can also be used as a master switch for the scooter's braking system. In the improbable event that the scooter should fail to stop or return to the off position, turning the key switch to the off position automatically and immediately causes the brake to engage and the scooter to come to a quick halt. Use great care in this situation to avoid an accident!

**ATTENTION:** When using the scooter key ring, DO NOT attach additional keys or accessories to the key ring. These additional weights, coupled with scooter vibrations, may cause the key to momentarily move to the OFF position. This occurrence may cause the scooter to come to a sudden stop.

**NOTE:** The battery indicator will tell you if power is applied. The indicator only works when the key is switched ON and all battery connections are made.

Your scooter is equipped with a battery saver circuit. It will shut off the controller after 20 minutes of non-use (even with your key "ON"). The system is reset by turning the key "OFF" and back "ON" again.

**2. SPEED SETTING KNOB.** Use this knob, located to the left of the key switch, to dial in the scooter's top speed and power. Rotate the dial counterclockwise toward the turtle (1) for use indoors or in tight areas where speed is not required. A higher setting toward the rabbit (10) is suitable for outdoors and open areas where higher speeds are manageable. When driving on difficult terrain or for persons with more limited physical control, use a lower top speed setting. If you set the knob between 5 & 10, the control's "power boost" feature will automatically increase power to maintain the top speed you are comfortable with. Should you not be able to use the speed control knob, your dealer can program the control for a slower top speed.

**3. BATTERY METER.** This meter indicates the charge condition of the batteries while you are driving. The batteries are in a good charge condition if the needle is in the green area while you are driving. The needle in the red area while driving corresponds to a low charge. It is possible to drive the scooter with the needle in the red area for a short time. You must charge the batteries as soon as possible. Refer to the battery charging section for more information.

**4. HORN.** The white button on the front of the control panel is the horn button. Simply pressing it sounds the horn.

**5. THROTTLE LEVER.** The black lever under the control panel is the throttle lever. Push the lever slowly with your thumb in the direction of the arrows on the control faceplate to make the scooter go forward or reverse. Pushing the lever in slightly will make the scooter begin to move. The further you depress the lever the faster the scooter moves. The top speed set by the SPEED knob is reached by fully depressing the throttle lever. Completely releasing the throttle bar will stop power to the motor and activate the brakes as you come to a complete stop. **EMERGENCY STOPS** - To stop quickly while driving in forward or reverse, change throttle bar direction (i.e. when going down an incline, to stop quickly move the throttle bar from forward to reverse.) Release the bar quickly to avoid driving in the opposite direction.

**PLEASE NOTE:** Should the throttle /brake control system not stop the unit, turning the key switch off will engage all brakes and bring the unit to a smooth stop. This backup system should only be used in the unlikely event that the primary brake control is disabled, as it puts an added stress on the components.



# "SOFT TOUCH" TILLER INFORMATION SHEET

## PACESAVER SCOOTERS ARE EQUIPPED WITH A "SOFT TOUCH" TILLER

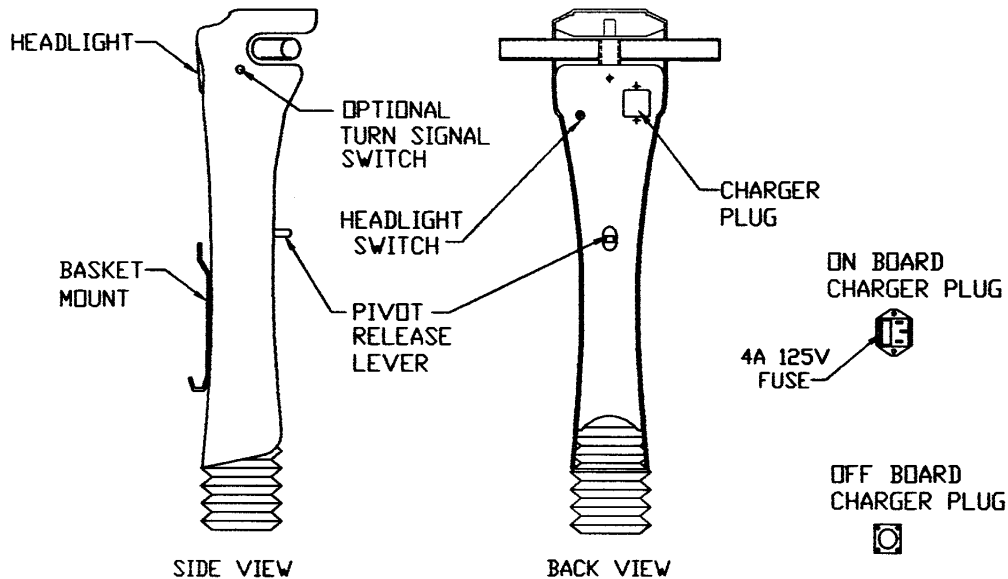

FIGURE 2

**HEADLIGHT** - The headlight is operated by the switch located on the back panel of the tiller.

**TURN SIGNAL** - If your scooter has the optional turn signals, it will have push button switches located on the sides of the tiller. **CAUTION:** The headlights and optional turn signals must be shut off after use to prevent discharging your batteries.

**TILLER PIVOT MECHANISM** - The tiller angle can be adjusted from vertical to horizontal. To make adjustments, push on the release lever while moving the tiller closer or farther away for yourself. Let go of the release lever to lock the tiller into position (See FIGURE 2).

### CHARGER CONNECTIONS

**ON-BOARD CHARGER** - If you have an on-board charger it will be mounted on the scooter. You will have a charger cord with a 110 VAC plug on one end and a 3 pin rectangular plug on the opposite end. Plug the cord into the rectangular charger port on the back plate and the opposite end into an AC outlet. Refer to the battery charging section in this manual for more information (See FIGURE 2).

**OFF BOARD CHARGERS** - If you have an off board charger, it will not be mounted on the scooter. You will have a charger with a cord having an AC plug on one end and a cord with a round plug on the other end. Connect the round plug to the tiller back plate and plug the AC cord to an AC outlet. Refer to the battery charging section in this manual for more information (See FIGURE 2).

**NOTICE:** The battery charger provided is specially designed for use with PaceSaver brand equipment. In the unlikely event of failure it should be replaced only with a PaceSaver approved charger to assure proper performance of the charger and scooter.

## **For your first ride we recommend the following.**

1. Make sure the area is flat, open and free of obstacles.
2. Make sure the tiller is properly adjusted to fit your driving needs. Refer to the "Soft Touch" Tiller section in this manual for more information.
3. Make sure the seat is in the locked position (handle is down).
4. Turn the SPEED setting knob to the turtle (1) .
5. Turn the key switch to ON.
6. Push the throttle lever on the "F" side ("F" for Forward) with your thumb to go forward.
7. SLOWLY rotate the SPEED setting knob from the turtle position. Rotate the knob until the desired top speed is reached.
8. Release the throttle lever to come to a stop. Take note of how the braking feels. The clicking you might hear upon starting and shortly after releasing the throttle lever is the Posi-Lock Electric Disk Brake disengaging and engaging.
9. Push the throttle lever on the "R" side ("R" for Reverse) with your thumb to go backward. There is a factory set forty percent (40%) reduction in speed in the reverse direction WITHOUT any change in the SPEED SETTING KNOB. Always make sure the area behind you is clear before backing up.
10. Remember to turn the key OFF when not driving or getting on or off the scooter.

### **WARNING**

*PaceSavers* are designed for high maneuverability, but use caution when encountering obstacles. Failure to drive cautiously can result in tipovers or collisions which may cause physical injury. When approaching an obstacle keep your speed at a minimum and maintain a safe distance from that object.

BE PREPARED TO STOP. Avoid any small objects on the ground. The scooter's ground clearance may be less than the size of the object. Running over an object or into a depression could cause overturning or damage to the scooter. **NEVER** ride the unit near platforms, stairs, ledges, curbs or in any other potentially dangerous situation as severe injury can occur.

### **WARNING**

PaceSaver Titan and Atlas models are high performance vehicles. As with Sport Utility Vehicles they require more caution when operating. Because of the extra power and speed they are more susceptible to tipping in rough terrain and tight turns at high speed. Serious injury can result. For that reason you should always use caution when operating at higher speed.

Remember, speed can be "Dialed Down" using the speed setting knob on the control console without losing power to run at the slower speed. If necessary, the unit can be permanently programmed by your dealer to operate at a speed more suitable for your control. Use caution while learning to operate this vehicle and consult your dealer if you have any problems. This unit should not be used by people with limited physical upper body strength.

## **The PaceSaver Braking Systems**

The *PaceSaver's* brake systems allow for smooth start up and safe braking without undue jerking. There are three (3) separate modes to the braking system: Regenerative, Dynamic, and Posi-Lock Electric Braking. All braking occurs automatically during scooter operation. Each type of braking is described in the following.

1. Regenerative Braking is activated while driving the *PaceSaver* down an incline. When the scooter picks up speed going down the incline, the motor generates electricity. This electricity is channeled back through the *PaceSaver's* electronic control circuits to recharge the batteries. This action keeps the scooter from picking up excess speed and provides for smooth speed control.

2. Dynamic Braking is activated WITHOUT delay when all power is stopped to the motor by releasing the throttle lever, as when coming to a complete stop. This braking works until the Posi-Lock Electric brake is activated.

3. Posi-Lock Electric Braking Disk is activated with delay when all power is stopped to the motor. This electric brake has a short delay and ultimately holds the *PaceSaver* at a complete stop. The scooter cannot be moved when this brake is activated. Dynamic Braking works in conjunction with Posi-Lock Electric Braking to bring you to a gradual and complete stop.

**PLEASE NOTE:** Should the throttle /brake control system not stop the unit, turning the key switch off will engage all brakes and stop the unit immediately. This backup system should only be used in the unlikely event that the primary brake control is disabled, as it puts an added stress on the components.

## **BRAKE DISENGAGE MECHANISM**

*The PaceSaver* is equipped with a manual Brake Disengage Mechanism. This mechanism allows the scooter to be moved in the event the batteries are run low, or if there is a malfunction.

### **Caution:**

**DO NOT** ride the *PaceSaver* with the Brake Disengage Mechanism activated at any time. Our "push-to-fast" circuit slows the unit down but does not stop it. **DO NOT** ride or sit on the scooter with these systems disengaged or if the brakes are inoperative. Have the system repaired immediately.

# MANUAL BRAKE RELEASE FOR ALL PACESAVER SCOOTERS

## Activating the disengage mechanism is as follows.

1. Be certain the scooter is on flat level ground.
2. Locate the Black release knob on the top right of the rear cover. Pull the black knob up firmly until the cart freewheels. This disengages the Posi-Lock disc brake but retains dynamic & regenerative motor braking if the key switch is turned on.
3. Always turn the key to the "OFF" position when the brake release is in the up position. This disengages the dynamic braking systems and initiates our exclusive "Push to Fast" braking system which activates if the scooter rolls beyond a crawling speed.

***Never sit on the scooter with the brake disengaged! The scooter can move unexpectedly and cause damage or injury.***

There is a label on the rear cover like this to help you operate the disengage.



## Deactivating the disengage is as follows.

1. First, press the black release knob back down until it is firmly seated in its original position to engage the "posi-lock" brake.
2. Second, turn the key to the "OFF" and then to the "ON" position. All braking systems are again activated and normal scooter operation may resume.

**SHOULD THE BRAKE DISENGAGE ON A SCOOTER EVER  
APPEAR TO WORK POORLY OR INCORRECTLY, STOP RIDING  
IMMEDIATELY AND CONTACT YOUR DEALER FOR SERVICE!**

## Seat Assembly Operation

*PaceSavers* come with three styles of armrests, each with their own adjustments. Each of these armrests is designed to provide support for your arms while you are seated on the scooter, and for some assistance when getting on and off of the scooter. **THEY ARE NOT DESIGNED TO HOLD A PERSONS WEIGHT!** Persons with limited use of their legs or without the ability to transfer their weight to the floor should seek additional assistance (slide board, helper, etc.) when transferring on and off of the scooter. Failure will result if excess weight is applied to the armrests.

<u>Fixed armrest adjustments</u>	<u>Variable Width armrest adjustments</u>	<u>Armrest height adjustments</u>
<p>Should the armrest angle change over time, you can adjust the angle back to level.</p> <ol style="list-style-type: none"> <li>1. Lift the armrest to the vertical position.</li> <li>2. Loosen one of the two nuts that hold the adjustment bolt in place..</li> <li>3. Turn the top nut, turning it up or down, depending on the needed adjustment, and test for the correct armrest height.</li> <li>4. When you have the correct angle, tighten the bottom nut.</li> </ol>	<ol style="list-style-type: none"> <li>1. Loosen the black knobs at the lower rear of the seat Rotate counter clockwise to loosen.</li> <li>2. Slide the armrests in or out as needed.</li> <li>3. Tighten the black knobs. Rotate clockwise to tighten.</li> </ol> <p>Should you wish to remove the armrests, simply pull them out when the knobs are loose. Remember to tighten the knobs to avoid their loss.</p>	<ol style="list-style-type: none"> <li>1. Remove the nut, bolt and wedges holding the two piece adjustable height armrest together.</li> <li>2. Raise or lower the inside piece of tubing to the preferred height.</li> <li>3. Install the nut, bolt and wedges used to hold the tow piece adjustable height armrest together.</li> </ol>

The *PaceSaver* seat rotates 360 degrees. The seatlock allows you to lock the seat in any position. Seatlock operation is as follows.

1. Rotate the seat to the desired position.
2. Push the lever forward firmly until it is down and the seat will not swivel.
3. When properly locked, the seat will not rotate while you are riding the scooter (see warning).

4. To unlock, pull up on the lever. The seat will now swivel freely. Take care when assembling the cart that the seat lock lever is upright and all the way down on the seat post to avoid damage to the seat lock mechanism and so that the seat slips on easily. Failure to do this will damage the seatlock!

**WARNING:** A scooter's seatlock IS NOT designed to hold the seat while you push off one side to assist yourself in standing! You risk injury if the seat is used in the wrong way! Do not attempt to overtighten the seat lock. If it does not hold under its intended use while you are riding the scooter, see the section regarding adjustment later in this manual, or contact your dealer immediately!

### **Seat Height Adjustment** (FIGURE 3)

The seat assembly height is adjustable. The factory places the seat in the next to the lowest possible position. On some styles, there are three higher positions in one inch increments. Owners of Atlas Series scooters should consult the Manual Addendum for additional details. The adjustment procedure is as follows.

1. Remove the seat assembly by unlocking the seat lock and lifting the seat assembly straight up and set it aside.

2. Locate the seat height adjustment bolt and nut located at the base of the chrome seat post (See figure 3).

3. Remove the nut, bolt, and small metal cones. Take note of their position in order to correctly replace them.

4. The chrome seat post will now slide up and down.

5. Position the chrome post to new desired height.

6. Replace the metal cones, bolt, and nut in their proper order. Tighten until all play is eliminated.

7. Replace the seat assembly and test the new height.

*It is recommended that the seat assembly be positioned at the lowest possible comfortable seat height. **PaceSaver** stability will be improved at the lower height.*

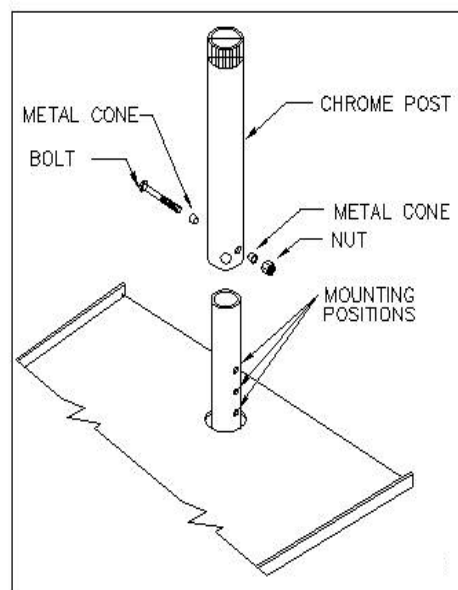
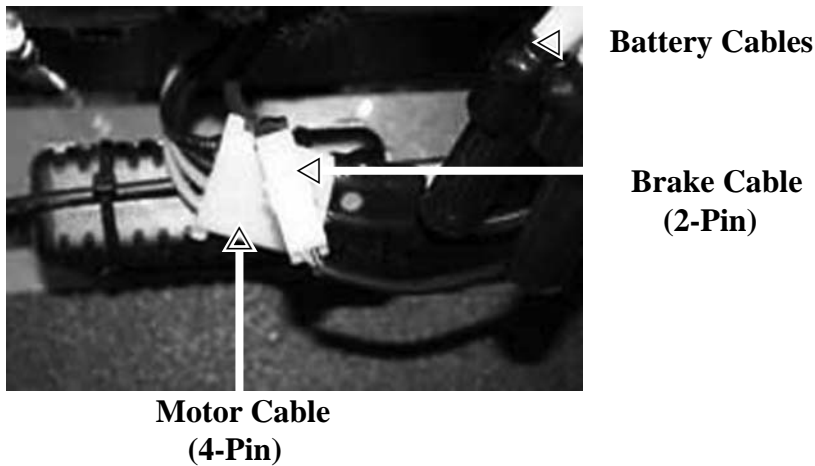

FIGURE 3

**500 lb capacity scooters** include separate disconnect plugs for the motor power and the motor brakes. To prevent possible damage of the plugs, it is important that you disconnect the smaller (2-pin) brake connector plug first. Locate the plugs above and slightly in front of the drive motor. (See FIGURE 4)

FIGURE 4



Pressing down on the latch release lever, pull the connector plugs apart with a rocking motion. (see FIGURE 5)

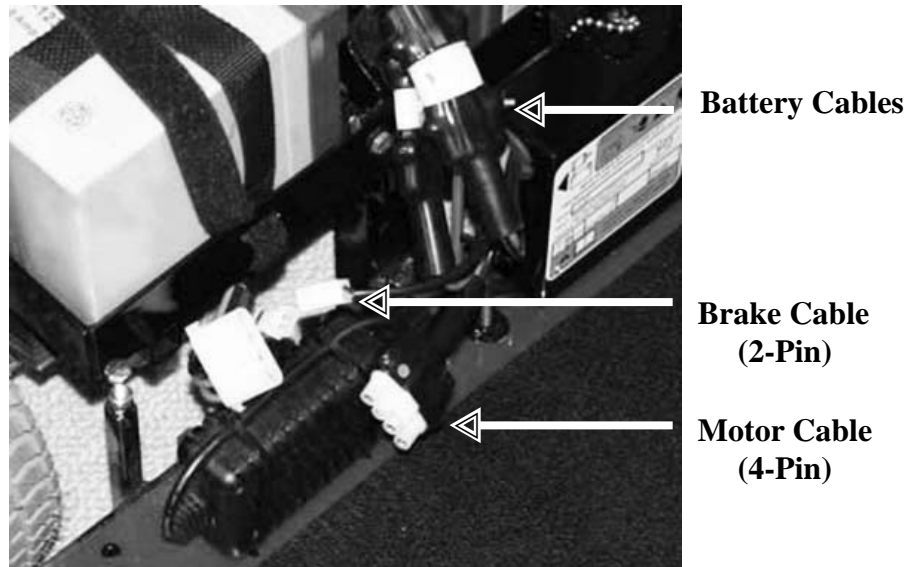

FIGURE 5

Reconnect the plugs in reverse order, (4-Pin) motor power connector first, followed by the (2-Pin) brake lead connector.

Use care to avoid pulling on the wires to disconnect the plugs.

## Disassembly and Assembly of the *PaceSaver Scooter*

The *PaceSaver's* patented separation makes it easy to disassemble and assemble. Complete disassembly can be accomplished in seconds WITHOUT tools.

1. Remove the key from the switch. (It should already be in the OFF position since it was placed there when you last got off the scooter).
2. Remove the armrests from the seat assembly if you find this more convenient.
3. Unlock the seat lock, lift the seat assembly upward and set it aside. Lift off the rear cover on units with one piece battery covers (Epsree, Eclipse, etc.).
4. Disconnect each battery. Depress the tab on the side of the three pin connector and pull the two connectors apart.
5. Unfasten the velco backed battery hold down straps and remove both batteries.

6a. Disconnect the smaller 2-pin brake cable connector (for the 500 lb Atlas Model only, see Figure 6).

6b. Disconnect the motor cable. (Depress the tab on the side of the single 4-pin connector and pull the two cable ends apart.)

7. Disconnect the motor cable. Depress the tab on the side of the single four pin connector and pull the two connectors apart.

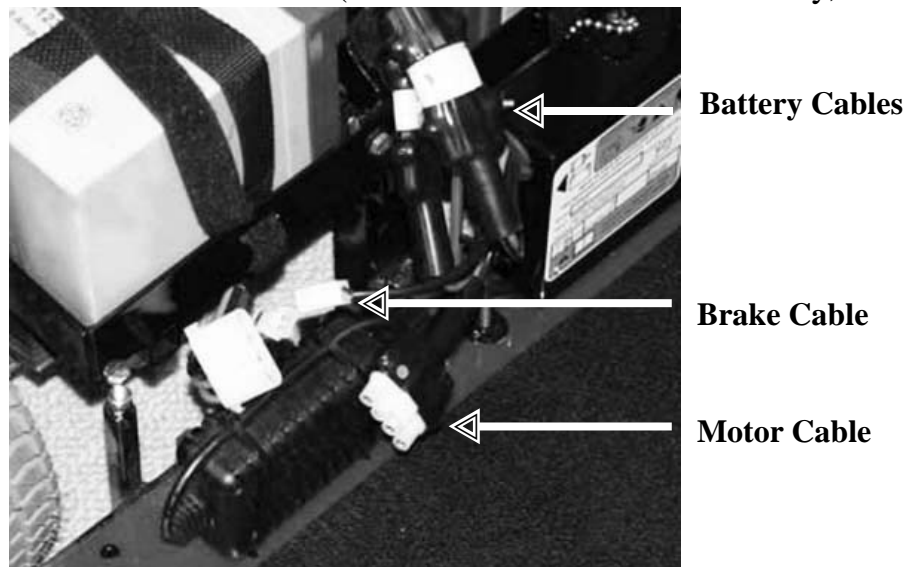
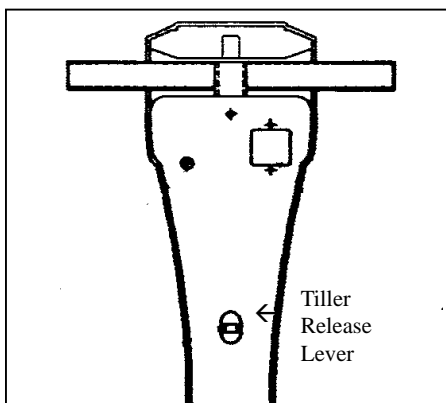

**FIGURE 6**

8. Pull up on the L-handle pull pin located just behind the chrome seat post.

9. Slide the front section away from the rear section. Use caution since the sections will rock to the ground once they become separated.

10. Push the tiller release lever to allow the tiller to pivot backwards toward the floor pan (See FIGURE 7).



**FIGURE 7**



**The following is the procedure for assembling the *PaceSaver Scooter*.  
With practice this will become easier and easier.**

1. Align the silver tongue of the rear section with the square tube on the front section. Check that there are no cables caught between the two sections. Both sections should be resting on the ground at this point (See FIGURE 8).

2. Begin to insert the tongue into the square tube by pushing down on the rear of the rear section while lifting up on the chrome seat post of the front section.

3. The two (2) sections will rock up and partially slide together. Once the sections cannot be lifted any higher, slide them together completely.



FIGURE 8

4. Insert the L-shaped pull pin into the hole just behind the seat post. Be certain pull pin is inserted completely to its stop ring. It may be necessary to line up the holes in the tube and the tongue before the pin can be inserted.

5. Push the tiller release and raise the tiller.

6a. Connect the large motor plug cable to the rear section. Push the plug straight in.

6b. Connect the two-pin brake plug cable for. (500 lb. Atlas Model only. see FIGURE 4 pg 21)

7. Put the batteries in place and securely fasten them down with the hold down straps.

8. Connect the battery cables. Align the receptacle and the plug. Push the plug straight in.

9. Place the seat assembly into the chrome seat post. Make sure the seat lock lever is in the unlock position to avoid damage. Rotate the seat assembly to insure it is lowered completely.

10. Get on the scooter, adjust the tiller, lock the seat lock, and go for a ride. Be sure to follow the warnings and instructions written in this manual for operating the scooter.

## **THE SCOOTER BATTERIES**

Charging the batteries is the most important part of operating and maintaining your scooter. Be sure to do it properly! **IMPORTANT:** Only AGM or gelcell sealed lead-acid deep cycle discharge type batteries should be used with this scooter. Do not use regular car starter batteries. AGM and gelcell batteries do not require water and they have no danger of spillage. Some are approved by the Federal Aviation Administration for air travel.

**NOTICE:** The battery charger provided is specially designed for use with PaceSaver brand equipment. In the unlikely event of failure it should be replaced only with a PaceSaver approved charger to assure proper performance of the charger and scooter.

### **Important Safety Information:**

Always use caution when lead-acid batteries are being charged. Batteries can generate explosive gasses during charging. Observe the follow guidelines to reduce risk of battery explosion.

1. Never smoke or allow open flame or sparks around a charging battery.
2. Never charge a frozen battery.
3. Use a PaceSaver charger designed for charging deep-cycle gelcell and AGM batteries.
4. The user is instructed to NOT use the charger with a battery configuration not matching the output voltage rating of the charger. The batteries in this scooter are connected for 24 volts.
5. The charger is rated at 24 volts DC and includes a special safety circuit to prevent operation of the scooter while charging. This is to prevent accidentally driving away with the AC cord connected, causing damage to the cord and to the receptacle in the user's residence.
6. Do not operate the charger in closed area or restrict ventilation around the charger in any way.
7. Do not disconnect the DC portion of the charger circuit while the AC cord is still connected to the electrical outlet. Unplug the AC cord first.
8. It is normal for the charger to operate at a high temperature. Do not touch the hot charger until after it cools.

### **Basic Safety Instructions:**

1. Do not expose the charger to rain, snow or other moisture sources (i.e., sprinkler, car wash, etc.). When storing the scooter, keep it inside a building or under a protective covering.
2. Use of the charger in a manner not recommended by the manufacturer may result in the risk of fire, electrical shock or personal injury.
3. To reduce the possibility of damage to the AC cord or the connector, disconnect the AC line cord by grasping the plug and not the cord, when disconnecting from either the cart or the wall receptacle.
4. Locate cord so that it will not be stepped on, tripped over or subjected to the possibility of damage.

5. An extension cord is not recommended for use with this equipment. Use of an improperly rated extension cord could result in risk of fire or electrical shock. Should it be required to use an extension cord, make certain that it is of 3-wire construction and has a wire size of at least 16-gage, and the cord must be in good electrical condition.
6. Do not operate this charger with damaged AC cord or receptacle. If they are damaged, replace them immediately.
7. Do not disassemble the charger. If there is a perceived problem with the equipment, refer to the servicing section of this manual or refer to a qualified technician for service. Incorrect assembly of the charger could result in a risk of electrical shock or fire.
8. Do not operate the charger if it has received an impact of a severity that may render it inoperative. Take it to a service technician.
9. To reduce the risk of electrical shock, unplug the charger from the electrical outlet before attempting any maintenance or cleaning.
10. Operate the charger on a flat surface. Restricting air flow around the charger can create an overheated condition. Carpeted floors can restrict air flow. It is normal for the charger to operate at a high temperature.
11. Do not operate the charger with a damaged cord or plug. Do not operate if the charger looks like it has been damaged. Contact your dealer for repair.
12. Make sure the charging plug is seated fully in the scooter battery charger outlet.
13. Do not stand on wet surface while connecting charger.

### **Before Charging:**

1. Verify that battery terminals are clean and that all charger connections are secure and in good condition.
2. Verify that all cords and cables are in good condition.

### **Grounding and AC Power Connection:**

The charger must be plugged into a grounded electrical outlet. The unit is provided with an electrical cord which contains a conductor for grounding. The charger cord must be plugged into an AC outlet that is properly installed, and is grounded in accordance with the National Electrical Code and all local electrical codes and ordinances.

**!! CAUTION !!** - *Failure to plug the charger into a grounded receptacle could cause a condition allowing an electrical shock hazard to be present while charging.*

**++DANGER++** *Improper connection of the equipment grounding conductor can result in a risk of electrical shock*

**!! CAUTION !!** - Never alter the AC cord or plug provided with this equipment. If it does not fit the outlet, have a properly grounded outlet installed by a qualified electrician.

A TEMPORARY AC ADAPTER may be used to connect the plug provided with this charger to a two-pole receptacle if a properly grounded receptacle is not available. The temporary adapter should only be used until a properly grounded outlet can be installed by a qualified electrician. The green colored tab on the adapter **MUST** be connected to a permanent ground such as a properly grounded outlet box.

**THE USE OF TEMPORARY ADAPTERS IS ILLEGAL IN CANADA AND SHOULD NOT BE USED. HAVE A QUALIFIED ELECTRICIAN INSTALL A GROUNDED OUTLET BEFORE USING THIS CHARGER.**

**!! CAUTION !!:** *Be certain the wall cord is disconnected from the electrical outlet before moving the scooter. Moving the scooter without disconnecting the wall cord could result in damage to the scooter, the cord and the wall outlet. This could create a shock hazard condition.*

**++WARNING++:** *Because you will be connecting and disconnecting AC to the scooter, be cautious of doing so in the presence of water (i.e., rain or puddled water). Electrical shock hazard could be present. Observe all caution and safety warnings.*

**++WARNING++:** *Lead-acid batteries generate gasses which can be explosive. Avoid smoking, sparks or open flames around charging batteries. Charge in an area with adequate ventilation.*

**++WARNING++:** *Chargers can cause small sparks that can ignite flammable materials and gasses. Do not use chargers near fuels, grain dust, solvents, thinners or other flammable materials. Charge in an area with adequate ventilation.*

---

**Information for California Residents: Compliance with Proposition 65**

**Warning:** This product (batteries) contains or emits chemicals known to the state of California to cause cancer and birth defects or other reproductive harm.

**Warning:** Battery posts, terminals and related accessories contain lead and lead compounds.  
**Wash hands after handling.**

## **Useful Battery Information**

1. The battery meter in the tiller's Control Console indicates the charge condition of the batteries while you are driving. The meter will not indicate the “true condition” while sitting still. The green area corresponds to a good charge. The red area corresponds to a low charge or to a deep cycle discharge condition. It is possible to drive the scooter for a short time with the batteries in a deep cycle discharge condition, but once they drop below a certain level of power the scooter will stop and leave you stranded. If while you are driving the meter falls into the red area, you must recharge the batteries as soon as possible. Recharging will bring deep cycle discharge condition batteries up to full charge. You will not achieve maximum battery life if the batteries are routinely run to the deep cycle discharge condition.

2. If batteries are discharged to red area (deep cycle discharge) they must be recharged immediately to avoid reducing the life of the batteries.

3. It is best to charge the batteries before they reach the deep cycle discharge condition. Shorter charge intervals keep a battery “topped off”. This reduces the charging time and maximizes the life of the battery.

### **USE THE BATTERY METER AS A BATTERY CHARGE CONDITION INDICATOR**

As you operate the scooter and become familiar with it you will notice that the battery meter on the control console will display a diminishing value as the charge in the batteries is consumed. The indicator of the meter will move through the green “good” area toward the yellow area (the reserve). Frequently discharging the batteries below the yellow area will reduce the life of the batteries.

For optimum battery life they should be recharged when the indicator on the battery meter is near the center of the dial, just before leaving the green "good" area, while you are driving.

The battery meter may be observed in the charge mode by turning the keyswitch to the “on” position while the charger is operating. You may now observe the charge being replenished in the batteries by the movement of the meter toward the “D” in “GOOD”. At some point around the “D” the basic recharge cycle is complete and the scooter may be operated with confidence that the batteries have been replenished to an optimum capacity.

The optimum discharge/recharge cycling of the batteries includes consideration for maximum usage of the scooter, maximum life of the batteries and minimum recharging time over the life of the batteries. Maximum usage of the scooter between recharges depends on the weight that the scooter carries, the speed that the scooter is driven and any obstacles the scooter must overcome such as ramps, curbs and hills.

Tips for increasing the range of the scooter:

- Reduce the weight carried on the scooter.
- Inflate the tires to the recommended pressures.
- Accelerate slowly by pushing gently on the throttle.
- Set the speed control knob to about two-thirds of maximum speed.
- Travel around obstacles whenever possible.
- Periodically check that all electrical connections are secure.

Tips for maximizing the battery life and reducing total recharge time:

- Always use the PaceSaver battery charger that is provided with the scooter.
- Park the scooter in the shade whenever possible.
- Avoid discharging the batteries below the green "GOOD" zone on the battery meter, (about 50 percent discharge level).
- Recharge until the "CHARGE" light on the charger turns off and the battery meter indicator is near the "D" of the word "GOOD". This would be 80 - 90 percent of full charge.
- Every ten or so recharge cycles leave the charger connected to the batteries for a few additional hours or overnight. This will bring the battery up to about 100 percent recharge level.
- Avoid subjecting the batteries to below zero freezing conditions.

# Offboard Battery Charger Instructions

The switch-mode battery charger provided is specially designed for use with your PaceSaver wheelchair. In the unlikely event of failure we recommend replacement only with a PaceSaver brand charger. The charger is intended for use with AGM or gelcell sealed lead-acid deep cycle discharge type batteries only. This is a 24 volt DC charger for use only with batteries connected for 24 volt DC service. Do Not use the charger with a car starter battery.

The PaceSaver brand battery charger includes

- Microprocessor control allows switch-mode operation for faster charging.
- Light weight and compact size offers space advantages.
- All units feature Auto Voltage Select (AVS): One unit operates for 100 VAC, 120 VAC or 230 VAC.
- Power limited battery charging (using algorithm) depending on battery state of charge.
- Automatic shutoff and restart to compensate for battery self discharge.
- Reliable charging achieved through a multi-stage, multi-mode charging algorithm.
- Thermal protection prevents damage from over temperature conditions.
- Input & output protected by automotive electronic sensor.
- Output current limit so as not to exceed the maximum power and/or thermal capacity.
- Output short circuit and reverse polarity protection.
- LEDs indicate AC Power ON, Charging Status and Fault Conditions.

**Refer to the instructions provided with the battery charger for detailed specifications and operation information.**

1. Connect the plug from the charger to the cart battery charger outlet located in the tiller (See FIGURE 2, page 15). Align the white mark on the connector and push firmly in until the plug is properly seated (See FIGURE 9). This assures proper connection to the batteries. **PLEASE NOTE:** For your safety the scooter is equipped with a charger safety lockout that will not allow the scooter to operate while the charger plug is plugged in.

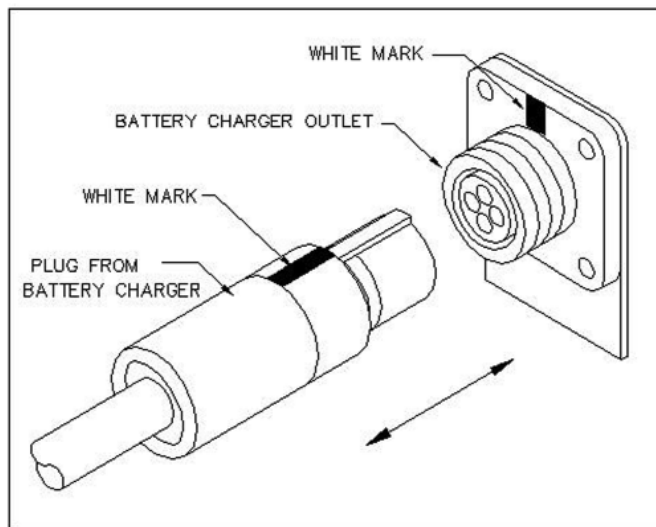

FIGURE 9

2. Insert the charger AC power plug into a properly wired household outlet.

3. Leave the charger on until the batteries are fully charged. This will be indicated by the chargers L.E.D. When this point is reached, the charger will go into monitoring mode. This mode can be left on indefinitely without any harm to the battery.

4. Before driving the scooter disconnect the charger AC Power plug from the household outlet.

5. Before driving the scooter remove the battery charger plug from the scooter connector.
6. Charts that show how long to charge a battery can be misleading. The only sure method is to use the charger's indication of charge completion.

The charger may be left connected to the scooter batteries in monitor mode to build and hold the charge at 100% without any damage to the batteries. Many other manufacturer's chargers cannot be left on without a fixed time limit.

*Note: The PaceSaver Battery Charger used must used according to the instructions. Failure to do so may damage or destroy the batteries, give poor range, or be potentially dangerous. Batteries should not be abused (for example by regularly deep discharging) and must be operated and maintained according to the instructions.*

*Note: Please refer to the Battery Charger Manual included with this user manual for further instructions, warnings and important information.*

**Warning: Do not disconnect batteries or open circuit the circuit breaker during charging. This is dangerous to both people and equipment.**



# *PaceSaver<sup>®</sup>*

## *"Onboard Battery Charger"*

Scooters equipped with the *PaceSaver Onboard battery charger* fully automatic battery charger, have a 24-volt Constant Current Charger. It is designed to operate from a 120-volt AC/ 60 Hz line source and provides a constant charging output until the batteries are fully charged. This results in a maximum charge in a minimum amount of time. Conventional chargers have a declining output proportionate to the charge rate of the batteries.

The *PaceSaver Onboard battery charger* is recommended for use with deep cycle AGM or gel sealed lead acid batteries, and can be left "on charge" indefinitely without harm to the batteries. Plus, the charger will operate from an AC line source as low as 100-volts and as high as 126-volts (47-63 Hz). Circuit protection is built into the device to protect the circuitry with reverse polarity protection and a fuse is located in the end of the charger case.

### **Charging Notes:**

Regular use of your scooter will require regular charging. It is a common misconception that lead-acid batteries need to be run into deep discharge before recharging. This is not true and can lead to damage of the batteries if they are frequently discharged deeply before recharge. Likewise, if batteries are stored for a long period of time without recharge, this may result in permanent damage to the batteries resulting in unreliable operation and shortened battery life. Maximum driving range of your scooter can be maintained if the batteries are fully charged prior to a lengthy storage period. Because the charger is fully automatic it can be left connected for up to 6 months without harm to the batteries.

### **Fuse:**

The *PaceSaver Onboard battery charger* is provided with an external replaceable fuse located on the end of the charger housing. The charger is located under the rear cover of the scooter, and on some equipment, you may need to remove the rear section from the scooter and turn it upside down to replace the fuse.

Replace this fuse with one of an identical rating and type. Use of a fuse of a different rating could result in a condition which could cause electrical shock potential or conditions resulting in fire. A second fuse is located in the AC connector found on the tiller.

### **Service/ Troubleshooting:**

Should your *PaceSaver Onboard battery charger* fail to perform:

1. First, check that all connections are properly made for a fully assembled scooter. On some equipment, the charger lines go through the motor plug, so if the motor plug is disconnected for some reason, then the charger will not function. Likewise, if the batteries are not connected, they will not receive a charge, and the meter will not give an indication.

2. Check that the wall outlet has power to it. The outlet may be on a switch and will not function if not switched on.
3. If all connections are properly made and the unit is connected to a working outlet, check the fuse in the charger (see Fuse section).

If these steps fail to produce satisfactory results, please refer to an authorized service center to have the system fully analyzed.

**How to Use This Charger:** With the scooter completely assembled:

1. Connect the AC power cord to the receptacle located on the scooter tiller (See FIGURE 10), and then to a properly grounded AC outlet (See FIGURE 11). (refer to grounding instructions) *As a safety feature, the scooter will not operate when the charger cord is plugged into the wall outlet and the charger is operating.*

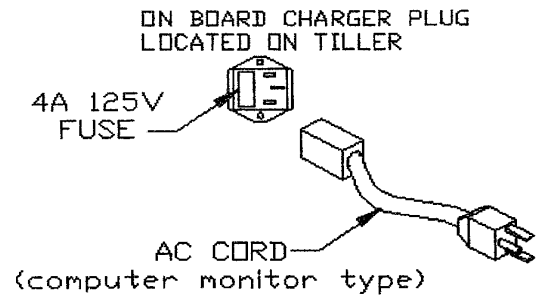

FIGURE 10

**!! CAUTION !!** : *Do not use connectors or cords that are cracked, corroded or do not make adequate electrical contact. Overheating and possible property damage may result if defective connectors are used.*

2. The LED's located on the scooter charger will indicate that the charger is giving service to the batteries. When fully charged, the Orange LED will turn to green

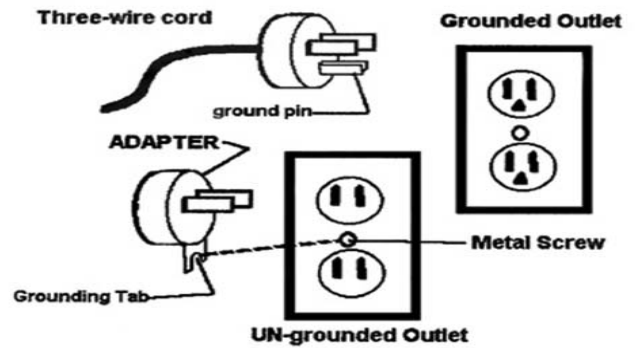

FIGURE 11

Because this is an automatic charger, the unit will have a constant charge rate when all is properly connected. This will continue at a steady rate until the batteries are approximately 90% charged, at which time the charger output will drop to less than 1 ampere. The charger will occasionally "wake up" when battery decay has fallen to below the cut-off voltage, and the charger will provide additional charge to "top off" the batteries.

3. After charging, remove the wall cord, first from the wall, then from the cart, and store it on the cart for future use.

# Storage of the *PaceSaver*

## Short Term and Overnight Storage

When ending *PaceSaver*'s use for the day, if the batteries do not need charging, simply turn the key OFF and remove it. The next morning, put the key in, get in, lock the seat, turn key ON and you are ready to go again. Should you leave the key on, the Battery Saver circuit shuts the system down after 20 to 30 minutes. To reactivate the unit, turn the key off, then back on.

## Long Term Storage

When the *PaceSaver* will not be used for an extended period of time, there are several things you should do to help maintain its proper working condition.

The *PaceSaver* and its batteries should only be stored in a dry environment with moderate temperatures. Long term exposure to excessive hot or cold temperatures will be harmful to the life of the batteries. The batteries must be fully charged before they are stored. They should remain connected to the *PaceSaver* charger for storage up to 6 months. Be sure that AC power remain's connected. If longer than 6 months the batteries should be exercised through a discharge/recharge cycle every one to two months.

## Maintaining the *PaceSaver*

In general, The *PaceSaver* is very easy to maintain. Consult your dealer if any repairs, adjustments, or damaged part replacements are needed.

## Routine Maintenance

### Daily

- Charge the batteries as described in the "Scooter Batteries" section of this manual.

### Weekly

- Check the tire pressure for proper inflation. See the proper specifications for your scooter.
  - Clean the *PaceSaver* using a damp cloth with a mild soap. Use a minimal amount of water.
- Do not allow electrical components to get wet. Wipe dry.

### Monthly

- Look the *PaceSaver* over in general making sure all the bolts and nuts are still tight.
- Inspect the battery wiring and motor connections for wear, damage, and that proper connections are made.
- Lubricate the top edge only of the seatpost tube with a light grease (See FIGURE 12).



FIGURE 12

## Twice a Year

- Inspect all wheels for looseness and tire wear.
- Clean the upholstery as needed.

## Yearly

- Thoroughly examine your scooter to look for undetected wear and other potential problems and have problems repaired immediately. The expense involved is always less than repair bills caused by a lack of proper maintenance. In the same way a car would not last forever without service, a scooter should be maintained regularly.

**AND REMEMBER!** If you ever notice any part of your *PaceSaver* scooter working in an improper or unsafe manner, stop riding it immediately and contact your dealer to arrange repairs. Do not use your scooter if there is a possibility it is not safe!

## Lubrication

Owners of scooters that are supplied with this manual **do not** need to lubricate their drive system. It is sealed and permanently lubricated.

## SEAT LOCK

The seat lock usually requires no adjustment, and will provide years of trouble free service. However, as time passes and surfaces begin to wear, you may need to remove one of the spacer washers (see exploded view) in order to tighten up the tolerances. To do this you need not remove the seatlock from the seatpost. First turn the seat upside down on a level surface and remove one of the two 1/4"-20 Bolts that hold the seatlock together. Then remove a washer that lies between the two halves of the seatlock ( this may leave one side with more washers than the other , that's O.K.). Be sure to reassemble the seatlock in exactly the same way it was disassembled and with all components in the proper place. If the seat lock works properly but still does not securely tighten the seat, another washer may be removed (this time from the opposite side). If it still operates incorrectly, contact your dealer immediately (See FIGURE 13).

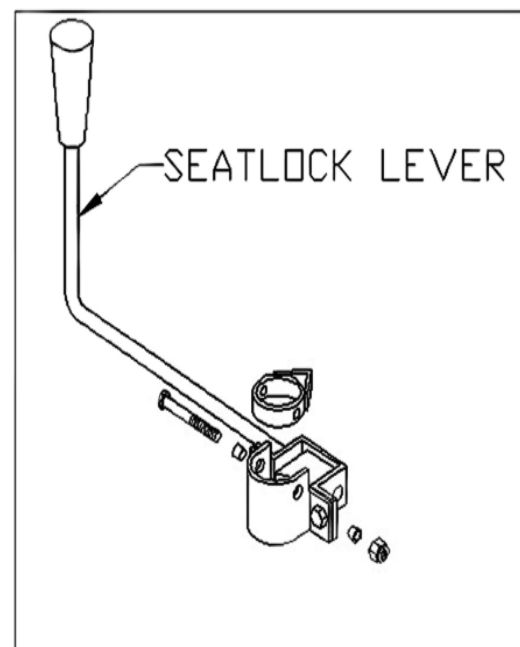

FIGURE 13

## **Tires**

The recommended pressure for the tires is listed below. **MAKE SURE** that you are using the specification for the STYLE *PaceSaver* that you own. Be careful not to overinflate. Properly inflated tires aid in the PaceSaver's efficiency. Under-inflated tires require more energy to roll, thus decreasing scooter performance. Under-inflated tires also affect the *PaceSaver* stability. A "soft" tire on one side, for example, can lead to overturning during cornering (under certain circumstances). Flat free tires are available if you are unable to check your tire pressure.

<b><u>ALL THREE WHEELED SCOOTERS</u></b>	<b><u>ALL FOUR WHEELED SCOOTERS</u></b>
50 PSI / 344.74 KPA	30 PSI / 206.84 KPA - 50 PSI / 344.74 KPA
Front & Rear	Front                      Rear

## **Warning**

DO NOT disassemble any wheel at any time for repairs while still inflated as the pressure may blow wheel rims apart while you are loosening them and serious injury may result. Completely deflate the tire first.

### **FOUR WHEELED FRONT ENDS**

**The *PaceSaver* four wheeled scooters have a front suspension system not unlike a cars. The *Eclipse* models are adjustable but the mechanism should be worked on by a professional. Should you feel that there is a problem with the steering and suspension, please contact your dealer. Otherwise the front end should be inspected yearly by a qualified *PaceSaver* service center.**

## Troubleshooting

1. Turn the keyswitch off, and then back on again.
2. Some styles have a visible circuit breaker. It is located on the black controller housing near the chrome seat post (See FIGURE 14). You will not see any white on the button when it is switched in the correct operating position. Also check to see that all of the wires are securely attached to the box.
3. Check the motor plug for proper connection.
4. Check the battery plug for proper connections.
5. Check the BATTERY indicator for discharged batteries.
6. Check that the Brake Disengage Mechanism is pushed all the way down.
7. Turn the keyswitch off, and then back on again.
8. If the scooter still will not move, consult the list of diagnostic codes on the next page. If they do not lead you to the source of the problem, contact your dealer.

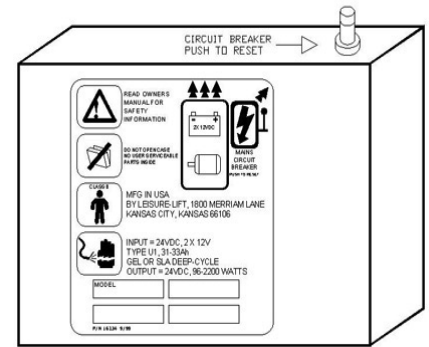

FIGURE 14

## DIAGNOSTIC INFORMATION

Leisure Lift products are known for excellent reliability and service. To further enhance this capability, your PaceSaver is equipped with a state of the art diagnostic system. While the system does indicate basic areas the user can check, it's primary purpose is to help your dealer identify the problem to get your scooter repaired as quickly as possible. When the key is on and the system detects a problem, the scooter will not run or will shut down. The BATTERY METER will MOVE continuously for about five (5) seconds. It will then proceed to flash a 2 part code. You may also depress the horn button during this diagnostic cycle and the horn will beep the codes in sync with the meter movement. Use the codes on the following chart to determine the proper corrective action. If the METER continues to MOVE after following the procedures in the LED Diagnostic Code chart, do not ride the scooter. Notify your dealer for repair.

<b>DIAGNOSTIC CODES (1108)</b>			
<b>ERROR CODE</b>	<b>PROBLEM</b>	<b>POSSIBLE CAUSES</b>	<b>CORRECTIVE ACTION</b>
1-1	Brake Short	Shorted brake, Loose/broken connection to brake, DC motor controller	Check wiring/plugs to motor/brake - consult dealer
1-2	Brake Open	Brake shorted to case, Missing/open brake, Loose/broken connection to brake, DC motor controller	Check wiring/plug to motor/brake-consult dealer
2-1	Motor Short	Bad motor, Loose/broken connection to motor, DC motor controller	Check wiring/plugs to motor-consult dealer
2-2	Motor Open	Bad motor, Loose/broken connection to motor, Brake manually released, DC motor controller	Check wiring/plugs to motor-consult dealer
2-3	Power Relay Short	Defective batteries, DC motor controller	Load test batteries - consult dealer
2-4	PSL Motor Short	PSL motor, Loose/broken connection to PSL motor, DC motor controller	Check wiring/plugs to motor - consult dealer
4-2	Charge Mode Time Out	Bad charger cable, Bad batteries, Bad charger, DC motor controller	Charging unit, charger plugged in, check wiring - consult dealer
5-3	Throttle Failband	Throttle control pot is off center/open, Loose/broken connection/cable, User interface, DC motor controller	Check throttle for center

## Commonly Asked Questions and Possible Answers

### Why has there been a loss of power?

1. Undercharged batteries. Check the BATTERY meter. The BATTERY meter indicates the charge condition of the batteries while you are driving. (The meter does not indicate the "true condition" while sitting still.) If, while you are driving, the meter needle falls into the yellow or red area, charge the batteries as soon as possible. Charging will bring batteries up to full charge.
2. The Posi-Lock Brake may not be releasing. This malfunction means the motor must overpower the brake to move, which requires a great deal of power. A rubbing sound can be heard during this type of malfunction.
3. Under-inflated tires. Check for proper inflation (check the specifications for your particular scooter).
4. Excessive weight on the cart. Remember that the *PaceSaver* takes a maximum of
  - 300 Lbs. - Plus III Premier & Espree Premier
  - 350 Lbs. - Plus III Titan, Espree Titan & Eclipse Premier
  - 450 Lbs. - Eclipse Atlas, Espree Atlas & Plus III Atlas
  - 500 Lbs. - Eclipse Atlas 5 & Espree Atlas 5
5. There may be other motor or driving mechanism malfunctions. Consult with your dealer.

### Is there a way to stop the cart, or apply the brakes, if the Brake Disengage Mechanism is out?

NO! THE BRAKE DISENGAGE MECHANISM DEFEATS COMPLETE BRAKING. Never sit on or ride the scooter in this situation! When pushing the unit, the "push-to-fast" system limits the speed should you lose control pushing down a hill.

### Will leaving the batteries unused for a long time damage them?

Yes. Storage of batteries is very important to their life span. The very best way to maximize battery life is to store them in a fully charged condition in a cool place. Then periodically (at least every 1-2 months!) charge to keep the batteries in this full charge condition. Do not store in cold or freezing temperatures. Batteries should never be subjected to freezing temperatures. Undercharged batteries can be ruined quickly in freezing conditions.

### Can a regular liquid lead-acid battery be used, like in a car?

No. A DEEP CYCLE battery must be used. A car battery is not intended for deep



cycle operation. A car battery would be ruined within a few days of operation in the scooter. Deep cycle batteries are available in both AGM sealed lead-acid and gel cell lead-acid. Either type can be used. These batteries are maintenance free and have no danger of spillage. Some are also approved by the Federal Aviation Administration for air travel. Do not use a conventional liquid flooded cell lead-acid deep cycle battery. Spillage of the battery acid can cause severe burns and will damage many components of your **PaceSaver**. The charger which came with the **PaceSaver** is designed specifically to charge AGM or gel cell batteries.

**Why will my PaceSaver not climb an incline?**

1. Excessive weight on the scooter for the grade of the incline. Refer to the Ramp Incline Chart in this Owner's Manual.
2. Batteries not fully charged, or are bad. Charge them and have them tested.
3. Under-inflated tires.
4. Attempting to go up the incline in reverse. Remember, there is a forty percent (40%) reduction in speed when moving in the reverse direction.

***Thank you for your purchase of a PaceSaver scooter. We hope that you will enjoy many years of trouble free service and freedom on your new scooter. Remember, your investment and your safety depend upon following the guidelines and suggestions contained in this manual.***

# Ramp Incline Chart

Degree of Incline	Ramp Length (In Feet)												Ramp Rise (In Inches)	Ramp Length (Inches)	Ramp Length (Feet)	Incline (degrees of slope)									
	2'	3'	4'	5'	6'	7'	8'	9'	10'	11'	12'	13'					14'	15'	16'	17'	18'	19'	20'	22'	24'
3"								1.5																	
4"				3	3	3	2.5	2	2																
5"				4	4	4	3.5	3	2.5	2	2														
6"				5	5	5	4	3.5	3	2.5	2	2													
7"				6	6	6	5	4	3.5	3	2.5	2	2												
8"				7	7	7	6	5.5	5	4	3.5	3	2.5	2											
9"				8	8	8	7	6	5.5	5	4	3.5	3	2.5	2										
10"				9	9	9	8	7	6	5.5	5	4	3.5	3	2.5	2									
12"				11	11	11	10	9	8	7	6.5	5.5	4.5	4	3.5	3	2.5	2							
14"				12	12	12	11	10	9	8	7	6.5	5.5	4.5	4	3.5	3	2.5	2						
16"				13	13	13	12	11	10	9	8	7	6.5	5.5	4.5	4	3.5	3	2.5	2					
18"				14	14	14	13	12	11	10	9	8	7	6.5	5.5	4.5	4	3.5	3	2.5	2				
20"				15	15	15	14	13	12	11	10	9	8	7	6.5	5.5	4.5	4	3.5	3	2.5	2			
22"				16	16	16	15	14	13	12	11	10	9	8	7	6.5	5.5	4.5	4	3.5	3	2.5	2		
28"				17	17	17	16	15	14	13	12	11	10	9	8	7	6.5	5.5	4.5	4	3.5	3	2.5	2	
35"				18	18	18	17	16	15	14	13	12	11	10	9	8	7	6.5	5.5	4.5	4	3.5	3	2.5	2
42"				19	19	19	18	17	16	15	14	13	12	11	10	9	8	7	6.5	5.5	4.5	4	3.5	3	2.5

9 degrees = 16%  
 12 degrees = 22%  
 15 degrees = 27%

RAMP INCLINE EXAMPLES

Ramp Rise	Ramp Length	Incline (Gov't Standard - Pub. Bldg.)
12" per 12"	12" per 12"	Incline (Gov't Standard - Pub. Bldg.)
12" per 19.5"	12" per 19.5"	Incline (Acceptable Private Residence for power/manual chair w/help)
12" per 11.5"	12" per 11.5"	Incline (Maximum for buildings)
12" per 8"	12" per 8"	Incline (Max for vehicles) - (NY State Max. Recommended Ratio)

# Addendum

## All "ATLAS" Models

PLEASE READ THE FOLLOWING INSTRUCTIONS CAREFULLY!  
THIS INFORMATION ONLY APPLIES TO ATLAS SCOOTER MODELS

### SEAT POST ADJUSTMENT

While the seat post adjustment works much the same as shown in your manual (Refer to seat assembly operation section in this manual for more information), there are some extra components used on the *ATLAS* for increased support. Please look at the drawing to the right and note the extra bracket that surrounds the seat post (part 22) and the small plastic insert that goes inside the seat post (part 21). If your unit is ever disassembled for any reason, please make sure these components are replaced as shown in the drawing.

### ANTI-TIP WHEELS

The *ATLAS* three wheeler comes equipped with front Anti-Tip wheels for additional safety (see part # 20 on FIGURE 15). DO NOT, under any circumstances, remove these Anti-Tip wheels. They are a required safety feature of the scooter and it should not be operated without them. If they cause a problem while maneuvering the scooter under certain circumstances, that should be your indication that the scooter should not be used in that manner!

### RAMP ANGLES

The *ATLAS* is rated for maximum 500 lbs rider on a 8° incline (14%) and should not be used on ramps steeper than that for safety reasons. If you do not know the exact angle of an incline you intend to traverse, please ask your dealer or some other individual to find out the degree of incline for you before using the scooter on that incline.

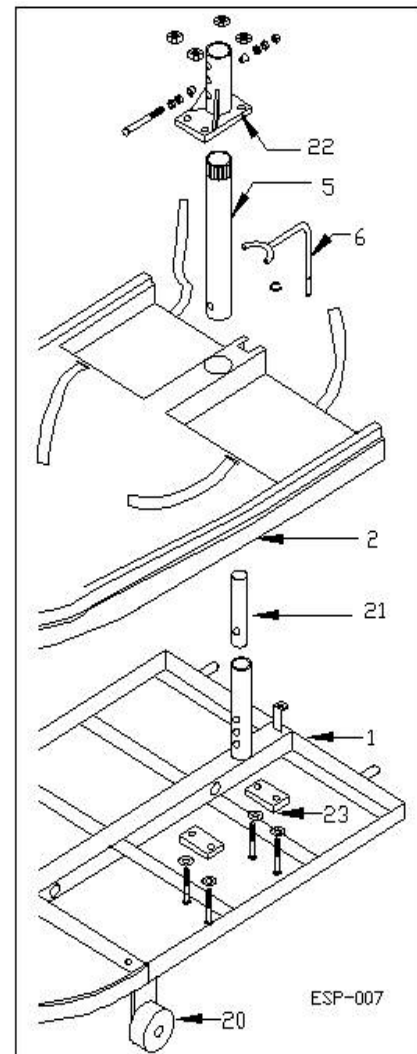

FIGURE 15

# Throttle Operated Power Seat Instructions

**CAUTION:** Only drive the scooter when the power seat is in the lowest position to avoid tipping.

## RAISING AND LOWERING THE SEAT

1. Position the DRIVE/SEAT switch to SEAT. A green LED will light up (See FIGURE 16).

**IMPORTANT:** Do not change the drive/seat switch position during operation (Doing so will cause the scooter to come to an abrupt stop). After releasing the throttle, wait two seconds for the controls to completely cycle off before changing the Drive/Seat switch or turning the key off. If the Drive/Seat switch is changed to the seat position while driving, the scooter will stop quickly. If the switch is changed to the drive position while running the seat or the key is turned off (before the controls have finished cycling) the scooter will move a few inches. Always wait the two seconds between operations.

**~ BE SURE those around you do not unexpectedly operate the switch. ~**

2. To raise the seat, depress the throttle bar in the FORWARD position.

**Note 1:** The seat motor will react just like the cart motor. The more pressure you put on the throttle bar the faster you go up.

**Note 2:** The speed adjustment knob position effects the speed of the seat motor. The fastest speed setting is 10.

3. To lower the seat depress the throttle bar to the REVERSE position.

**Notes 1 & 2 apply.**

## RESUMING TO DRIVE MODE

1. Your scooter is equipped with a safety sensor that will prevent you from driving if the power seat is raised more than 1" or it is swiveled sideways. If either of these two conditions occur, the seat motor LED on the throttle will be lit even if the selector on the throttle is set to "Drive". The light will go off once you lower the seat and/or rotate it forward and wait 2 seconds after releasing the throttle.

2. Make sure the seat is within an inch of its lowest position.

3. Make sure the swivel seat is facing forward and is locked into place by the handle on the side of the seat. **CAUTION: Failure to have the seat facing forward while driving could cause the safety sensor discussed above to become activated bringing the scooter to an abrupt stop.**

4. After the seat has been lowered and locked facing forward, wait two seconds, position the DRIVE/SEAT switch on the throttle to DRIVE and proceed with normal operation.

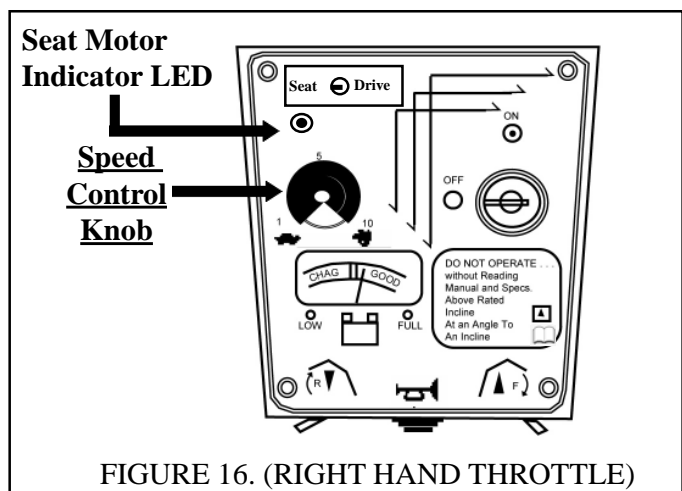

FIGURE 16. (RIGHT HAND THROTTLE)

## ELECTROMAGNETIC INTERFERENCE

**CAUTION: IT IS VERY IMPORTANT THAT YOU READ THIS INFORMATION REGARDING THE POSSIBLE EFFECTS OF ELECTROMAGNETIC INTERFERENCE ON YOUR POWERED WHEELCHAIR / POWERED SCOOTER.**

### Electromagnetic Interference (EMI) From Radio Wave Sources

Powered wheelchairs and powered scooters (in this text, both will be referred to as powered wheelchairs) may be susceptible to electromagnetic interference (EMI), which is interfering to electromagnetic energy (EM) emitted from sources such as radio stations, TV stations, amateur radio (HAM) transmitters, two-way radios, and cellular phones. The interference (from radio wave sources) can cause the powered wheelchair to release its brakes, move by itself, or move in unintended directions. It can also permanently damage the powered wheelchair's control system. The intensity of the interfering EM energy can be measured in volts per meter (v/m). Each powered wheelchair can resist EMI up to a certain intensity. This is called its "immunity level." The higher the immunity level, the greater the protection. At this time, current technology is capable of achieving at least a 20 v/m immunity level, which would provide useful protection from the more common sources of radiated EMI.

There are a number of sources of relatively intense electromagnetic fields in the everyday environment. Some of these sources are obvious and easy to avoid. Others are not apparent and exposure is unavoidable. However, we believe that by following the warnings listed below, your risk to EMI will be minimized.

The sources of radiated EMI can be broadly classified into three types:

- 1) **Hand-held portable transceivers** (transmitters-receivers) with the antenna mounted directly on the transmitting unit. Examples include: citizens band (CB) radios, "walkie talkie," security, fire, and police transceivers, cellular telephones, and other personal communication devices. **\*\*NOTE:** Some cellular telephones and similar devices transmit signals while they are ON, even while not being used;
- 2) **Medium-range mobile transceivers**, such as those used in police cars, fire trucks, ambulances, and taxis. These usually have the antenna mounted on the outside of the vehicle; and
- 3) **Long-range transmitters and transceivers**, such as commercial broadcast transmitters (radio and TV broadcast antenna towers) and amateur (HAM) radios.

**NOTE:** Other types of hand-held devices, such as cordless phones, laptop computers, AM/FM radios, TV sets, CD players, and cassette players, and small appliances, such as electric shavers and hair dryers, so far as we know, are not likely to cause EMI problems to your powered wheelchair.

## **Powered Wheelchair / Scooter Electromagnetic Interference (EMI)**

Because EM energy rapidly becomes more intense as one moves closer to the transmitting antenna (source), the EM fields from hand-held radio wave sources (transceivers are of special concern). It is possible to unintentionally bring high levels of EM energy very close to the powered wheelchair's / scooter's control system while using these devices. This can affect powered wheelchair movement and braking. Therefore, the warnings listed below are recommended to prevent possible interference with the control system of the powered wheelchair.

### **WARNINGS**

Electromagnetic interference (EMI) from sources such as radio and TV stations, amateur radio (HAM) transmitters, two-way radios, and cellular phones can affect powered wheelchairs. Following the warnings listed below should reduce the chance of unintended brake release or powered wheelchair movement which could result in serious injury.

- 1) Do not operate hand-held transceivers (transmitters-receivers), such as citizens band (CB) radios, or turn ON personal communications devices, such as cellular phones, while the powered wheel-chair is turned ON;
- 2) Be aware of nearby transmitters, such as radio or TV stations, and try to avoid coming close to them;
- 3) If unintended movement or brake release occurs, turn the powered wheelchair OFF as soon as it is safe;
- 4) Be aware that adding accessories or components, or modifying the powered wheelchair, may make it more susceptible to EMI (Note: There is no easy way to evaluate their effect on the overall immunity of the powered wheelchair / scooter);
- 5) Report all incidents of unintended movement or brake release to the powered wheelchair manufacturer, and note whether there is a source of EMI nearby.

### **Important Information**

- 1) 20 volts per meter (v/m) is a generally achievable and useful immunity level against EMI (as of May 1994) (the higher the level, the greater the protection).
- 2)  This model of *PaceSaver* vehicle has a minimum immunity level of 20 volts per meter (20 v/m).
- 3)  The immunity level of this model *PaceSaver* vehicle is unknown.

Dear Friend:

Thank you so much for your purchase of a *PaceSaver* Scooter! We value your trust in us and we will do everything we can to keep you happy. You're in a special group now. Thousands of people before you have trusted Leisure-Lift to provide them with the highest quality mobility products available. They and you have made *PaceSaver* the most valuable scooter.

We hope that you have read the Owners Manual completely, and that you understand all of the safety precautions and recommendations that apply to your particular scooter. If you have any questions, please ask your *PaceSaver* dealer. They can help explain any points that you do not understand.

In addition, your dealer will be glad to help you with any of your other *PaceSaver* needs. Situated close to you, they are in the best position to provide you with assistance and service.

The enclosed warranty card must be filled out in order for Leisure-Lift to:

1. effectively warranty your product in case of a problem
2. to properly follow the guidelines laid down by the Food & Drug Administration and to
3. allow us to locate you in the event of a product recall or modification

We also ask several questions about you to help us better understand the needs of our customers. The information you provide us helps to keep our scooters at the leading edge of quality and functionality and we hope that we can count on you to help us. Leisure-Lift always values the options of our customers and you may write us at any time to relate to us your "*PaceSaver* Experience" good (or not so good).

REMEMBER. . . It is in your best interest to see that you (not your dealer) properly complete this card and see that it is returned to Leisure-Lift.

Leisure-Lift®, PaceSaver® and Titan® are registered trademarks. Espree™, Eclipse™, Junior™, Premier™, Plus III™, Soft-Touch™, Com-For-Back™, and Atlas™ are all trademarks of Leisure-Lift®, Inc.  
© 2005 Leisure-Lift®, Inc. All rights reserved.

## **PaceSaver® LIMITED WARRANTY**

Leisure-Lift®, Inc. warrants, to the original PURCHASER, or to the DEALER, that each new *PaceSaver* will be free from defects in material and workmanship under normal use and service for a period of . . .

**THREE YEARS** -on the front & rear steel base frame. - on the *PaceSaver* Premier's transaxle (Premier's only)

**ONE YEAR FROM** date of purchase, or 15 MONTHS from date of shipment from the factory, whichever is shorter, on component parts.

**SIX MONTHS** on batteries purchased from Leisure-Lift, Inc. (Many dealers supply their own batteries.)

No warranties will be extended by Leisure - Lift, Inc. on these batteries.

*PaceSaver* Premier series Transaxles have a **FIVE YEAR LIMITED** parts warranty

(Parts cost only) **Year one** - 100% motor, brake & transaxle, **Year two** - 50% motor, brake & transaxle and

**Years three thur five** - 50% transaxle

All parts that are defective, as determined by the factory, will be replaced free of charge within the warranty period (see above warranty for details. This Warranty from Leisure-Lift DOES NOT INCLUDE LABOR, either at your home or at your dealer's place of business. During the warranty period, Leisure-Lift, Inc. may, at it's discretion, determine it is necessary to return the *PaceSaver* to the factory for repair. Leisure-Lift, Inc. will provide parts and labor free of charge for problems considered to be covered under our warranty. The customer is responsible for all freight charges including scooter shipped to the factory.

Failure to properly service the scooter at the intervals prescribed by the owners manual, abuse or faulty service may void this limited warranty and can result in charges for parts and service. All rights under this limited warranty must be exercised within 20 days after the end of the warranty. This warranty does not apply to any *PaceSaver* that meets any of the following conditions and Leisure-Lift, Inc. is not responsible for accidents or damage caused by:

- 1.) Abuse or misuse of the vehicle,
- 2.) Use of the scooter by any individual over the prescribed weight limit.
- 3.) Commercial use, this includes scooter rental.
- 4.) Parts which become defective , worn, damaged or broken due to
  - A.) The use of replacement parts not supplied by Leisure-Lift, Inc.
  - B.) Servicing by anyone not authorized by Leisure-Lift, Inc
  - C.) Electrical or mechanical modifications of the scooter by other than Leisure-Lift, Inc.

NOTE; DISASSEMBLING, MODIFYING AND/OR TAMPERING IN ANY UNAUTHORIZED MANNER WITH THE SCOOTER WILL VOID THE WARRANTY. Leisure-Lift, Inc. reserves the right to make engineering changes, additions, or improvements upon its current product without obligation to install the same upon its products previously manufactured.

# PaceSaver Extended Limited Warranty

## Qualifications and Guidelines

*This is your guide to receiving the benefits of Leisure-Lift's Extended Limited Warranty coverage. Read it carefully and follow all instructions!*

The Leisure-Lift company will extend the following EXTENDED LIMITED WARRANTY provisions to qualified owners of PaceSaver vehicles manufactured after January 1, 1994.

### The EXTENDED LIMITED WARRANTY is defined as the following:

A "LIFETIME" Warranty on your frame components (consult your dealer for specific components).

A "TWO YEAR" prorated Parts Warranty.

One year parts replacement at no charge (100%) parts replacement.

Second year parts replacement at half off (50%) of current retail parts prices on parts covered under this warranty.

This warranty DOES NOT include labor or transportation cost either to your dealer or back to Leisure-Lift. Regular labor charges apply.

**EXTENDED WARRANTY NO COST TO YOU:** A One Hundred Dollar Retail Value.

### HOW TO ENROLL:

You must fill out and return the "EXTENDED WARRANTY REGISTRATION" form in the envelope in which you received this form within 15 days of purchase (date on receipt). You must include in the envelope a copy of your proof of purchase (receipt, etc) to Leisure-Lift. You will then receive your official EXTENDED LIMITED WARRANTY CERTIFICATE".

### TERMS AND CONDITIONS

You must be in possession of an EXTENDED WARRANTY CERTIFICATE from Leisure-Lift in order to receive coverage under Leisure-Lift's extended warranty program. IF YOU DO NOT RECEIVE YOUR CERTIFICATE WITHIN 30 DAYS OF SUBMITTING YOUR REGISTRATION AND PROOF OF PURCHASE, CONTACT THE DEALERSHIP FROM WHICH YOU PURCHASED YOUR SCOOTER AND HAVE THEM CONTACT Leisure-Lift. If Leisure-Lift did not receive your original registration and proof of purchase you will be required to resubmit proof of purchase. Warranty is not transferable.

All other terms and conditions of Leisure-Lift's regular PaceSaver warranty apply.  
Failure to return a completed registration form within the time limits will void this offer.

Cut along dotted line

**Yes, I want to register my warranty and apply for my "EXTENDED LIMITED WARRANTY"!**

I have

1. Enclosed my proof of purchase and
2. Completely filled out the registration information below.

Please send me my Warranty Certificate by return mail. I understand that I must have the certificate to receive extended coverage and that if I do not receive my warranty certificate within 30 days, I should contact the dealership from whom I purchased the unit.

DEALER NAME (if different from above) \_\_\_\_\_

YOUR NAME \_\_\_\_\_

ADD1 \_\_\_\_\_

ADD2 \_\_\_\_\_

CITY, ST, ZIP \_\_\_\_\_

PHONE \_\_\_\_\_ / \_\_\_\_\_ Date Purchased \_\_\_\_/\_\_\_\_/\_\_\_\_

*For Service Call*

Dealer: \_\_\_\_\_  
City, St.: \_\_\_\_\_  
Your Serial Number is: \_\_\_\_\_

This Warranty has been sponsored by my dealer

**YES, please send me my Extended Warranty Certificate.**   
**I certify that I have read and understand the owners manual and all of the safety information contained within.**  
(sign) \_\_\_\_\_

To help us better understand our customers, we would like to know a little about you. Please fill in all the information you can.

AGE: \_\_\_\_\_ WEIGHT: \_\_\_\_\_ HEIGHT: \_\_\_\_\_